

FLEXIBLE COUPLINGS – N-EUPEX, N-EUPEX DS SERIES

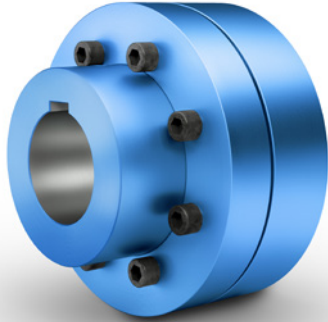

General	7/2
Benefits	7/2
Application	7/2
Design and configurations	7/3
Modular principle of N-EUPEX types	7/5
Technical specifications, N-EUPEX series	7/8
Assignment of N-EUPEX sizes to IEC standard motors	7/10
Type A for easy elastomer flexible replacement	7/11
Type B	7/12
Type B with clamping elements	7/13
Type DK for large misalignment with simple installation and removal	7/14
Type DKS	7/15
Type H	7/16
Type D for easy elastomer flexible replacement	7/18
Type E	7/20
Type P with brake drum	7/22
Type O with brake drum	7/24
Type DBDR with brake disk	7/26
Type ABD with brake disk	7/28
Type ERN with slip unit	7/29
N-EUPEX DS series	7/31
General	7/31
Technical specifications, N-EUPEX DS series	7/31
Type ADS for easy elastomer flexible replacement	7/32
Type BDS	7/33
Type HDS	7/34
Spare and wear parts	7/36



GENERAL

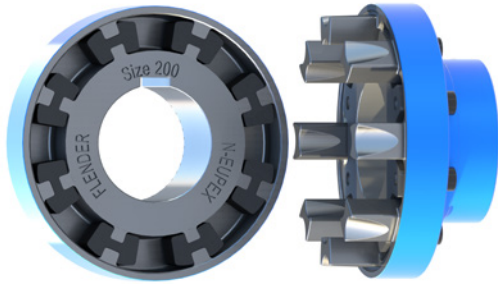

N-EUPEX as overload-holding, fail-safe series

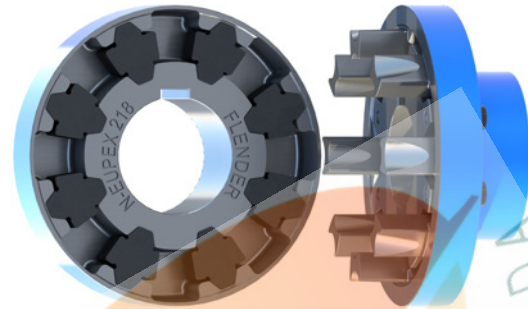

N-EUPEX DS as overload-shedding, non-fail-safe series

N-EUPEX and N-EUPEX DS pin couplings connect machines. They compensate for shaft misalignment, generating only low restorative forces. The torque is conducted through elastomer flexibles, so the coupling has typically flexible rubber properties.

N-EUPEX couplings are overload-holding. By contrast, the N-EUPEX DS series is designed so that overload or advanced wear causes irreparable damage to the elastomer flexibles. The metal parts of N-EUPEX DS couplings can then rotate freely against one another without contact.



Coupling suitable for use in potentially explosive atmospheres.

Complies with the current ATEX Directive for:

CE  II 2G Ex h IIC T6 ... T4 Gb X

 II 2D Ex h IIC T85 °C ... 110 °C Db X

 I M2 Ex h Mb X

Benefits

N-EUPEX couplings are designed on the modular principle and have a very simple construction. N-EUPEX types are made up of subassemblies to suit requirements. The couplings are assembled by simply fitting the coupling halves together. Wear is restricted to the elastomer flexibles, which must be replaced at the end of their service life.

Depending on type, the elastomer flexibles can be changed without moving the coupled machines.

The coupling parts are readily available from stock and are mostly finish-machined, i.e. with finished bore, keyway, set screw and balancing.

Application

The N-EUPEX coupling is available as a catalog standard in 23 sizes with a rated torque of between 28 Nm and 71000 Nm. The coupling is suitable for ambient temperatures of between -30 °C and +80 °C. By using alternative elastomer flexibles, the permissible ambient temperature range can be extended to between -50 °C and +100 °C. Frequently, the coupling is used to connect the motor to the gear unit input shaft. The coupling is suitable especially for drives with uniform to average dynamic loads.

Examples of applications are pump drives, ventilator drives or crane running gear. Furthermore, N-EUPEX couplings can be used as add-on couplings, particularly on FLUDEX fluid couplings or ARPEX AKR safety couplings. In the case of drives with a diesel engine, N-EUPEX couplings are suitable for driven machines with a low mass moment of inertia. In the case of diesel engine drives, the actual dynamic coupling load should be checked by measurement or torsional vibration calculations.

Design and configurations

N-EUPEX and N-EUPEX DS couplings consist of two coupling halves mounted on the machine shafts. The coupling parts are connected positively by means of elastomer flexibles. On the two-part variant, the elastomer flexibles can be changed only if one of the coupled machines is moved.

On the three-part variants, the bolted cam ring can be released and moved to enable the flexible to be changed without moving the coupled machines.

Elastomer flexible of the N-EUPEX series



The flexibles of the N-EUPEX coupling are subjected to compression. This results in progressive torsion spring characteristics. If the flexibles are irreparably damaged, the hub parts come into contact with metal. This causes the torque to continue to be transmitted in "emergency mode" for a short period of time.

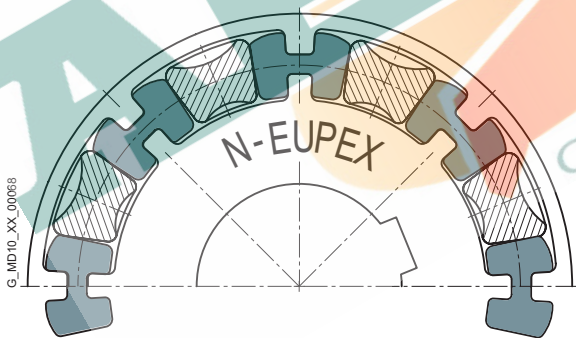

Elastomer flexible of the N-EUPEX DS series



The flexibles of the N-EUPEX DS series are subjected to compression and bending forces. A linear torsion spring characteristic curve is characteristic in this regard. If the flexibles are irreparably damaged, the metal parts turn against one another without contact, and the power transmission is separated. Fitting new flexibles will make the coupling once more usable. The capacity of the N-EUPEX DS series to shed overloads is especially in demand for highly sensitive machines.

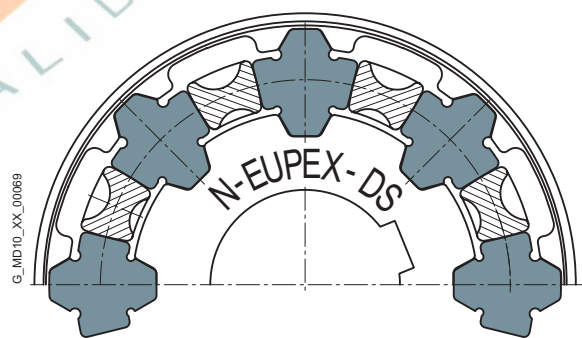

GENERAL

Materials

All coupling parts such as cam parts, pocket parts, spacers, hub parts and mounting parts are manufactured from high grade cast iron with lamellar or spheroidal graphite, or from steel. The sleeve pipes of the type DK spacers are made from aluminum.

Flexible materials

Material/description	Hardness	Marking	Ambient temperature
N-EUPEX series			
NBR standard type	80 ShoreA	Flexible black with blue stripe	-30 °C ... +80 °C
NBR electrically insulating	80 ShoreA	Flexible green	-30 °C ... +80 °C
NBR soft	65 ShoreA	Flexible black with green stripe	-30 °C ... +80 °C
HP (TPU) (size 80 to 280)	97 ShoreA	Flexible blue	-50 °C ... +80 °C
HP (NBR) (size 315 to 710)	90 ShoreA	Flexible black, fabric reinforced	-30 °C ... +80 °C
HP (NBR) (size 58 to 68)	90 ShoreA	Flexible black with magenta stripe	-30 °C ... +80 °C
NBR normal low-backlash	80 ShoreA	Flexible black with yellow stripe	-30 °C ... +80 °C
NBR soft low-backlash	65 ShoreA	Flexible black with white stripe	-30 °C ... +80 °C
NR for low temperature	80 ShoreA	Flexible black with orange stripe	-50 °C ... +50 °C
HNBR high temperature	80 ShoreA	Flexible black with red stripe	-10 °C ... +100 °C
Type N-EUPEX DK/DKS			
HP (TPU) (size 80 to 280)	97 ShoreA	Flexible blue	-50 °C ... +80 °C
HP (NBR) (size 68)	90 ShoreA	Flexible black with magenta stripe	-30 °C ... +80 °C
N-EUPEX DS series			
NBR hard	90 ShoreA	Flexible black	-30 °C ... +80 °C

The technical data do not include the flexible variants NBR low-backlash, HNBR high temperature and NR low temperature. Technical data, prices and article numbers can be found at www.flender.com

Standard types of N-EUPEX and N-EUPEX DS pin coupling

Type	Description
A	Fail-safe, 3-part
B	Fail-safe, 2-part
D	Fail-safe, 3-part, flange variant
E	Fail-safe, 2-part, flange variant
DK	Fail-safe, double-cardanic, with spacer
DKS	Fail-safe, double-cardanic, short length
H	Fail-safe, with adapter
P	Fail-safe, 3-part, with brake drum
O	Fail-safe, 2-part, with brake drum
DBDR	Fail-safe, 3-part, with brake disk, brake disk radially dismountable
ABD	Fail-safe, 3-part, with brake disk
ERN	Fail-safe, 2-part, with slip unit
ADS	Non-fail-safe, 3-part
BDS	Non-fail-safe, 2-part
HDS	Non-fail-safe, with adapter

Special types of N-EUPEX pin coupling on request

Type	Description
AT	Fail-safe, 3-part, with Taper clamping bush
BT	Fail-safe, 2-part, with Taper clamping bush
F	Fail-safe, 3-part, with intermediate shaft
G	Fail-safe, 2-part, with intermediate shaft
K	Fail-safe, 3-part, with brake drum to customer's requirement
L	Fail-safe, 2-part, with brake drum to customer's requirement
M	Fail-safe, 2-part, with flange dimensions to SAE J620d
DBD	Fail-safe, 3-part, with brake disk
EBD	Fail-safe, 2-part, with brake disk

Further application-related coupling types are available. Dimension sheets for and information on these are available on request.

Modular principle of N-EUPEX types

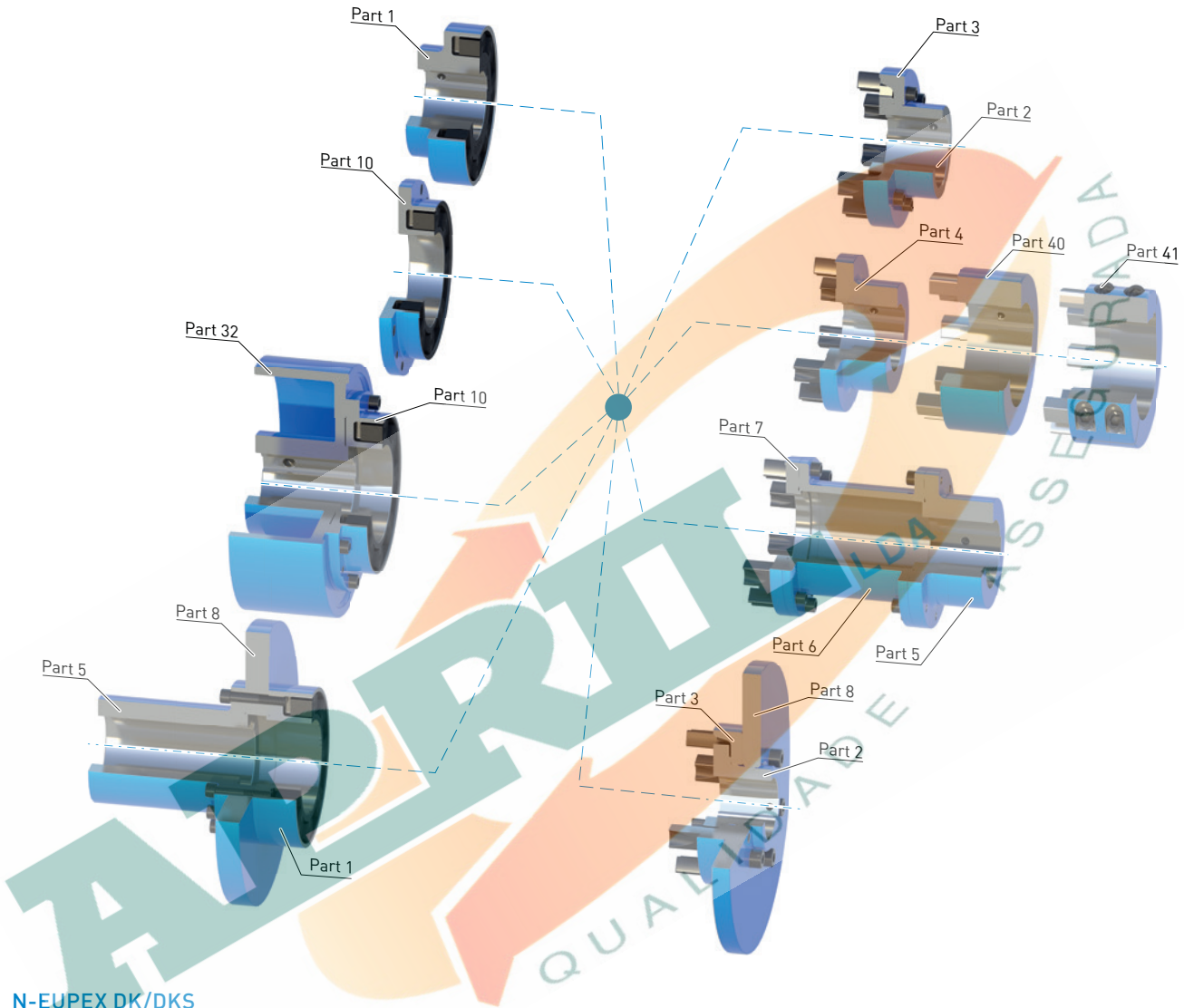

N-EUPEX DK/DKS

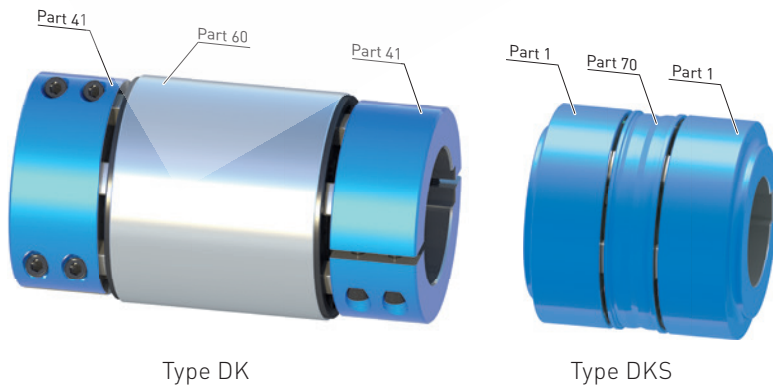

In the case of larger radial misalignment, double-cardanic N-EUPEX couplings can be supplied in addition to the modular system. The spacer (part 60 resp. 70) is centered with the help of the N-EUPEX elastomer elements. Any radial misalignment that emerges between the shaft ends will accordingly be equalized through a corresponding tilt angle in the elastomer joints with this two-joint versions. In the DK version, the separated hubs (part 41) made from steel facilitate simple installation. The DKS version is characterized by a reduced shaft distance.

GENERAL

Types N-EUPEX

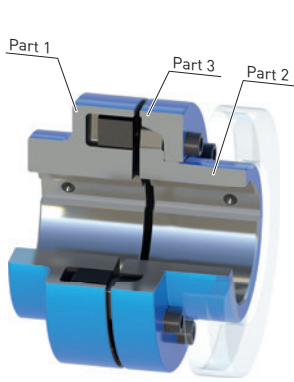

Types A and ADS

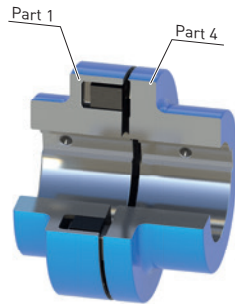

Types B and BDS

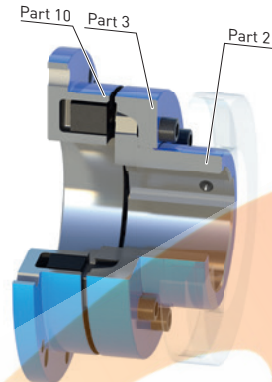

Type D

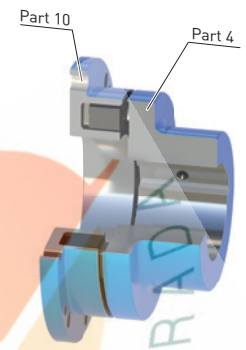

Type E

Types N-EUPEX with adapter

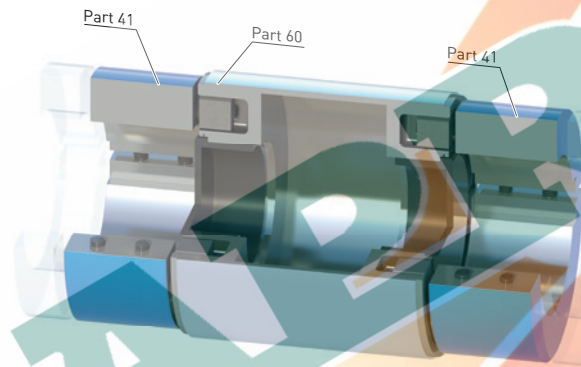

Type DK

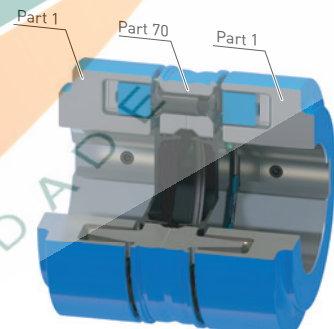

Type DKS

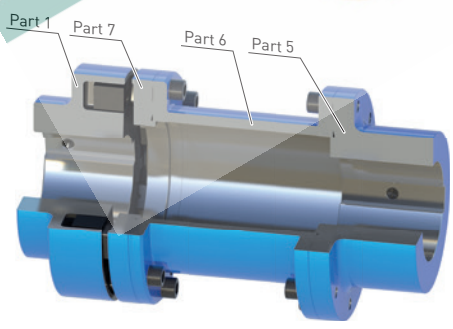

Types H and HDS

Type N-EUPEX with brake disk/brake drum

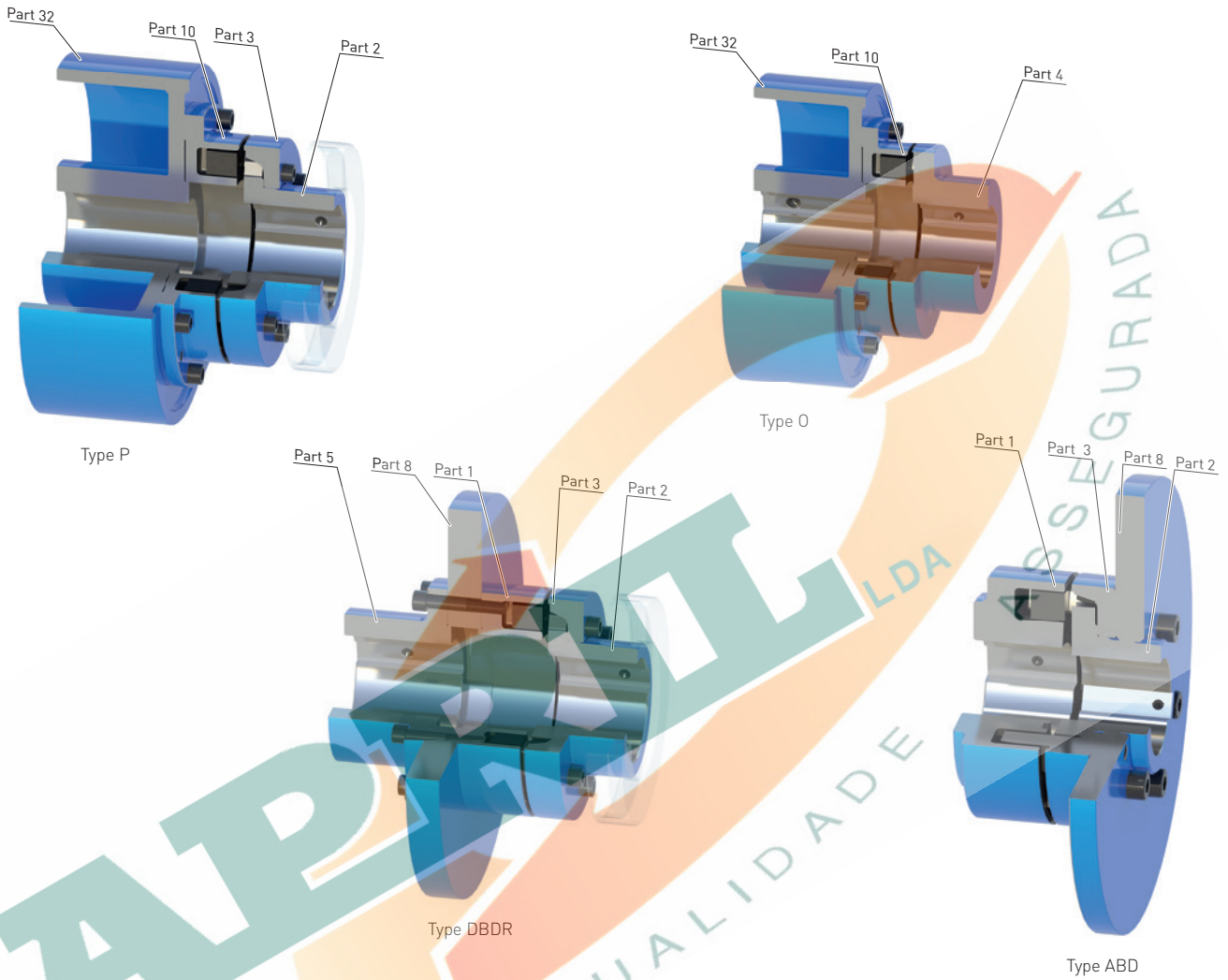

Type N-EUPEX with torque control

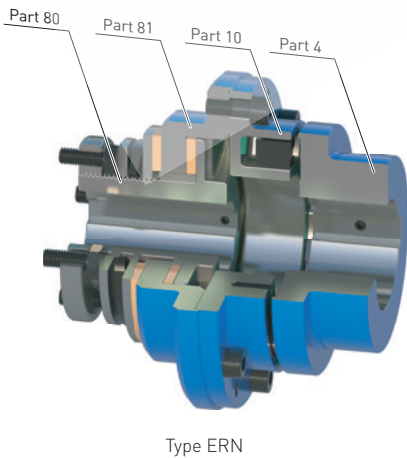

Note

- Further application-specific coupling types are available. Dimension sheets for and information on these are available on request.

GENERAL

Technical specifications, N-EUPEX series

Size	Rated torque for flexible type			Maximum torque		Torsional stiffness at 50 % capacity utilization for flexible type			Permitted shaft misalignment at speed ¹⁾ n = 1500 rpm	
	65 ShoreA	80 ShoreA	HP ²⁾	65 ShoreA	80 ShoreA / HP	65 ShoreA	80 ShoreA	HP	Radial	Angle
	T_{KN} Nm	T_{KN} Nm	T_{KN} Nm	T_{Kmax} Nm	T_{Kmax} Nm	$C_{Tdyn 50\%}$ kNm/rad	$C_{Tdyn 50\%}$ kNm/rad	$C_{Tdyn 50\%}$ kNm/rad	ΔK_r mm	ΔK_w °
58	12	28	34	36	85	0.22	0.75	1,51	0.2	0.15
68	23	48	58	69	145	0.42	1.26	2,79	0.2	0.15
80	40	85	120	120	300	1.13	3.21	14,2	0.2	0.12
95	69	140	200	207	500	1.77	5.32	23,1	0.2	0.12
110	110	225	325	330	812	2.70	8.15	36,1	0.2	0.10
125	165	345	490	495	1225	4.0	12.3	53,6	0.25	0.10
140	250	500	700	750	1750	6.0	18	77,8	0.25	0.10
160	385	840	1200	1150	3000	12.2	39.4	162	0.3	0.10
180	600	1250	1750	1800	4375	20.6	63.6	270	0.3	0.10
200	935	1950	2650	2800	6625	34.2	106.8	426	0.3	0.09
225	1380	2300	3400	4150	8500	52	131	619	0.35	0.09
250	1930	3900	5500	5800	13750	73	221	927	0.35	0.08
280	2700	5500	7400	8100	18500	103	313	1261	0.4	0.08
315	3850	7100	9350	11550	23375	186	472	1130	0.4	0.08
350	5335	10800	13000	16000	32500	255	708	1450	0.5	0.08
400	7150	14000	18000	21450	45000	343	997	2250	0.5	0.08
440	9350	19000	25000	28050	62500	427	1280	3200	0.6	0.08
480	11550	25100	33000	34650	82500	550	1781	4100	0.6	0.07
520	14630	32400	42000	43890	105000	650	2124	4800	0.65	0.07
560	20130	39000	50600	60390	126500	1095	3119	7600	0.65	0.07
610	26400	49000	63800	79200	159500	1422	3873	9400	0.75	0.07
660	33990	63000	79000	101970	197500	1799	4834	11300	0.8	0.07
710	42900	71000	93500	128700	233750	2339	5608	13400	0.9	0.07

For coupling fatigue torque:
 $T_{KW} = 0,15 \cdot T_{KN}$, where $T_N > T_W$ must be adhered to.

N-EUPEX shaft distance S and radial misalignment ΔK_r

N-EUPEX (single-joint coupling)

Radial misalignment ΔK_r and angular misalignment ΔK_w as well as changes in gap dimension are equalized in a elastomer joint. Values for ΔS can be found in the respective type selection tables.

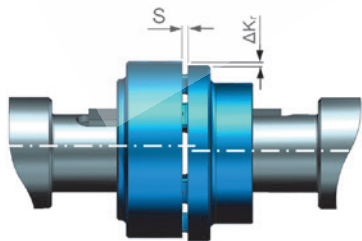

N-EUPEX DK/DKS (two-joint coupling)

Radial misalignment ΔK_r and angular misalignment ΔK_w as well as changes in gap dimension are equalized in two elastomer joints. Values for ΔS can be found in the corresponding type selection tables.

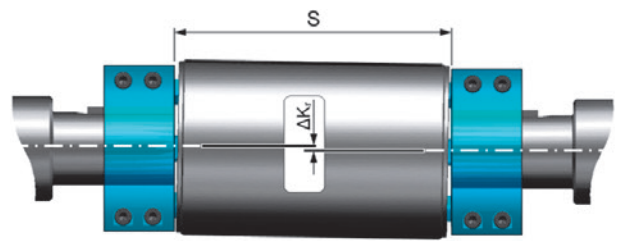

¹⁾ The maximum speed for the respective type must be noted. For additional information on the allowable shaft misalignment, please refer to the operating instructions.

²⁾ For sizes 80 to 280, in case of higher temperatures the temperature factor FT according to the table on page E/19 in the Introduction has to be considered.

Performance data for type N-EUPEX DK (two-joint coupling)

Size	Rated torque		Torsional stiffness at 50 % capacity utilization for flexible type HP $C_{Tdyn\ 50\%}$ kNm/rad	Permitted shaft misalignment ¹⁾ at $n = 1500$ rpm					Type DKS ΔK_r mm	Angle ²⁾ ΔK_w °
	HP T_{KN} Nm	HP T_{Kmax} Nm		Radial Type DK		Type DKS				
				S=100 mm $\Delta K_{r\ 100}$ mm	S=140 mm $\Delta K_{r\ 140}$ mm	S=180 mm $\Delta K_{r\ 180}$ mm	S=200 mm $\Delta K_{r\ 200}$ mm	S=250 mm $\Delta K_{r\ 250}$ mm		
68	48	120	1.18	1.2	-	-	-	-	-	0.15
80	85	212	5.6	1.2	1.7	-	-	-	0.5	0.12
95	140	350	9	1.1	1.6	-	-	-	0.5	0.12
110	225	562	14	1.1	1.5	2.1	-	-	0.6	0.10
125	345	862	21	1.0	1.5	2.0	2.3	-	0.6	0.10
140	500	1250	31	1.0	1.4	1.8	2.1	2.7	0.7	0.10
160	840	2100	63	-	1.3	1.8	2.1	2.7	0.7	0.10
180	1250	3125	107	-	1.3	1.8	2.0	2.6	0.7	0.10
200	1950	4875	170	-	1.2	1.7	2.0	2.6	0.8	0.09
225	2300	5750	240	-	-	1.7	1.9	2.6	0.9	0.09
250	3900	9750	370	-	-	-	-	-	1.1	0.08
280	5500	13750	525	-	-	-	-	-	1.1	0.08

For coupling fatigue torque:
 $T_{KW} = 0,15 \cdot T_{KN}$, where $T_N > T_W$ must be adhered to.

**Torsional stiffness and damping
 (single-joint or two-joint coupling)**

The values stated in the above table apply to a capacity utilization of 50 %, an excitation amplitude of 10 % T_{KN} with frequency 10 Hz and an ambient temperature of 20 °C. The dynamic torsional stiffness is load-dependent and increases in proportion to capacity utilization. The following table shows the correction factors for different rated loads.

$C_{Tdyn} = C_{Tdyn\ 50\%} \cdot FKC$

	Load T_N / T_{KN}						
	20 %	40 %	50 %	60 %	70 %	80 %	100 %
Correction factor FKC							
65/80 ShoreA							
HP (size 58–68, 315–710)	0,50	0,82	1,00	1,20	1,40	1,63	2,10
HP (size 80 – 280)	0,55	0,85	1,00	1,14	1,29	1,42	1,69

The damping coefficient is $\Psi = 1.4$ for the 65/80 ShoreA packages and $\Psi = 1.2$ for the HP package

Furthermore, torsional stiffness and damping depend on the ambient temperature, on the frequency and on the amplitude of the torsional vibration excitation. More precise torsional stiffness and damping parameters on request.

Due to the manufacturing process and ageing of the elastomers, the tolerance for the dynamic stiffness is $\pm 20\%$.

**Permitted shaft misalignment
 (single-joint or two-joint coupling)**

The permitted shaft misalignment depends on the operating speed. As the speed increases, lower shaft misalignment values are permitted. The correction factors for different speeds are specified in the following table. The maximum speed for the respective coupling size must be noted!

$\Delta K_{perm} = \Delta K_{1500} \cdot FKV$

	Speed in rpm			
	500	1000	1500	3000
Correction factor FKV	1.7	1.2	1.0	0.7

For fitting, the maximum gap dimension of $S_{max.} = S + \Delta S$ and the minimum gap dimension of $S_{min.} = S - \Delta S$ are permitted.

Shaft misalignments ΔK_r and ΔK_w may occur simultaneously.

¹⁾ The maximum speed for the respective type must be noted. For additional information on the allowable shaft misalignment, please refer to the operating instructions.
²⁾ The angular misalignment ΔK_w refers to the maximum additional tilting of the shaft axes.

GENERAL

Assignment of N-EUPEX sizes to IEC standard motors (selected operating factor = 1.25) ¹⁾

Three-phase motor Size	Output at ≈ 3000 rpm		Output at ≈ 1500 rpm		Output at ≈ 1000 rpm		Output at ≈ 750 rpm		DE (ASI) shaft end D x E acc. to IEC	
	P_M kW	N-EUPEX size	P_M kW	N-EUPEX size	P_M kW	N-EUPEX size	P_M kW	N-EUPEX size	D mm	E mm
56	0.09	58	0.06	58					9	20
56	0.12	58	0.09	58					9	20
63	0.18	58	0.12	58					11	23
63	0.25	58	0.18	58					11	23
71	0.37	58	0.25	58					14	30
71	0.55	58	0.37	58					14	30
80	0.75	58	0.55	58	0.37	58			19	40
80	1.1	58	0.75	58	0.55	58			19	40
90 S	1.5	58	1.1	58	0.75	58			24	50
90 L	2.2	58	1.5	58	1.1	58			24	50
100 L	3	68	2.2	68	1.5	68	0.75	68	28	60
100 L			3	68			1.1	68	28	60
112 M	4	68	4	68	2.2	68	1.5	68	28	60
132 S	5.5	80	5.5	80	3	80	2.2	80	38	80
132 S	7.5	80							38	80
132 M			7.5	80	4	80	3	80	38	80
132 M					5.5	80			38	80
160 M	11	80	11	95	7.5	95	4	80	42	110
160 M	15	80					5.5	95	42	110
160 L	18.5	80	15	95	11	95	7.5	95	42	110
180 M	22	95	18.5	110					48	110
180 L			22	110	15	110	11	110	48	110
200 L	30	110	30	125	18.5	110	15	125	55	110
200 L	37	110			22	125			55	110
225 S									55	110
225 S			37	125			18.5	125	60	140
225 M	45	110							55	110
225 M			45	140	30	140	22	140	60	140
250 M	55	125							60	140
250 M			55	140	37	140	30	140	65	140
280 S	75	140							65	140
280 S			75	180	45	180	37	180	75	140
280 M	90	140							65	140
280 M			90	180	55	180	45	180	75	140
315 S	110	140							65	140
315 S			110	180	75	180	55	180	80	170
315 M	132	160							65	140
315 M			132	180	90	180	75	180	80	170
315 L	160	160							65	140
315 L	200	160							65	140
315 L			160	200	110	200	90	200	80	170
315 L			200	200	132	200	110	200	80	170
315 L					160	200	132	225	85	170
315	250	180							65	140
315	315	200							65	140
315			250	225	200	250			85	170
355	355	200							75	140
355	400	200							75	140
355	500	225							75	140

¹⁾ Outputs P_M of IEC motors and assigned N-EUPEX couplings (80 ShoreA)

TYPE A

for easy elastomer flexible replacement

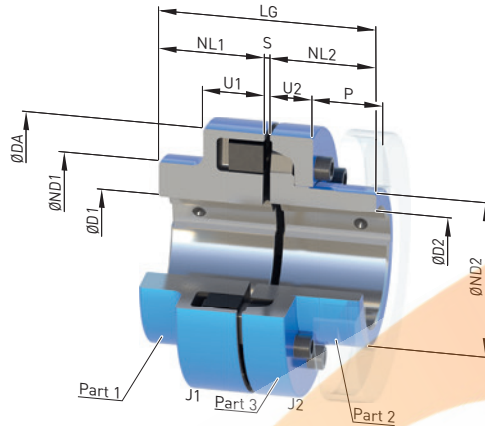

Size	Rated torque flexible type 80 ShoreA T_{KN}	Speed n_{Kmax}	Dimensions in mm														Mass moment of inertia J_1/J_2	Article no. ¹⁾	Weight m
			Bore with keyway to DIN 6885-1		D1		D2		DA	ND1 ²⁾	ND2	NL1/NL2	S	ΔS	U1	U2			
	Nm	rpm	min.	max.	min.	max.						±					kgm ²		kg
110	225	6300	-	55	-	45	110	86	60.5	40	3	1.0	34	20	33	83	0.002	2LC0170-4AB	2.7
125	345	6100	-	60	-	55	125	100	73.5	50	3	1.0	36	23	36	103	0.004	2LC0170-5AB	4.2
140	500	5800	-	65	-	60	140	100	80.5	55	3	1.0	34	28	43	113	0.007	2LC0170-6AB	5.6
160	840	5100	-	70	-	70	160	108	93.5	60	4	2.0	39	28	47	124	0.013	2LC0170-7AB	7.8
180	1250	4500	-	80	-	80	180	125	106	70	4	2.0	42	30	50	144	0.023	2LC0170-8AB	11
200	1950	4000	-	85	-	90	200	140	119	80	4	2.0	47	32	53	164	0.04	2LC0171-0AB	16
225	2300	3600	-	90	-	100	225	150	135	90	4	2.0	52	38	61	184	0.07	2LC0171-1AB	23
250	3900	3300	46	100	-	115	250	165	153	100	5.5	2.5	60	42	69	205.5	0.13	2LC0171-2AB	32
280	5500	3000	49	110	54	125	280	180	168	110	5.5	2.5	65	42	73	225.5	0.20	2LC0171-3AB	42
315	7100	2600	49	120	45	145	315	200	196	125	5.5	2.5	70	47	78	255.5	0.37	2LC0171-4AB	61
350	10800	2400	61	140	60	165	350	230	226	140	5.5	2.5	74	51	83	285.5	0.64	2LC0171-5AB	85
400	14000	2000	66	150	65	180	400	250	246	160	5.5	2.5	78	56	88	325.5	1.1	2LC0171-6AB	119
440	19000	1900	80	160	80	190	440	265	261	180	7.5	2.5	86	64	99	367.5	1.7	2LC0171-7AB	156
480	25100	1800	90	180	90	215	480	300	296	190	7.5	2.5	90	65	104	387.5	2.7	2LC0171-8AB	199
520	32400	1500	100	190	100	225	520	315	310	210	7.5	2.5	102	68	115	427.5	3.8	2LC0172-0AB	251
560	39000	1500	120	200	120	230	560	320	316	220	9	3.0	115	80	125	449	5.3	2LC0172-1AB	303
610	49000	1300	130	220	130	250	610	352	348	240	9	3.0	121	88	135	489	8.2	2LC0172-2AB	393
660	63000	1200	140	240	140	275	660	384	380	260	9	3.0	132	96	145	529	12.3	2LC0172-3AB	501
710	71000	1100	140	260	140	300	710	416	412	290	9	3.0	138	102	155	589	17.4	2LC0172-4AB	623

Configurable variants ¹⁾

- ØD1 Without finished bore
With finished bore
- ØD2 Without finished bore
With finished bore

Notes

- Weights and mass moments of inertia apply to maximum bores.

Ordering example

- N-EUPEX A coupling, size 200
- Part 1: Bore D1 65H7 mm, keyway to DIN 6885-1 and set screw
- Part 2: Bore D2 50H7 mm, keyway to DIN 6885-1 and set screw

Article no.: 2LC0171-0AB99-0AA0 L1F+M1C

¹⁾ To identify complete item numbers specifying the available finish boring options and – if necessary – further order options, please use our configurators on flender.com.

²⁾ The hub diameter HD1 can be smaller for small bores.

↗ For online configuration on flender.com, click on the item no.

TYPE B

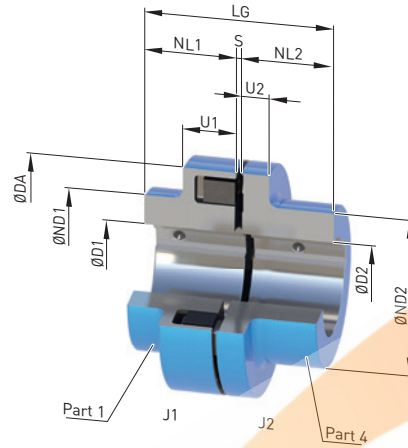

7

Size	Rated torque flexible type 80 ShoreA T_{KN} Nm	Speed n_{Kmax} rpm	Dimensions in mm Bore with keyway to DIN 6885-1										Mass moment of inertia J_1/J_2 kgm ²	Article no. ¹⁾	Weight m kg				
			D1		D2		Part 40 ²⁾	DA	ND1	ND2	NL1/ NL2	S				ΔS	U1	U2	LG
			min.	max.	min.	max.		max.						+/–					
58	28	9000	–	22	–	25	32	58	58	40	20	3	1.0	20	8	43	0.0001	2LC0170-0AA	0.4
68	48	8400	–	28	–	30	40	68	68	50	20	3	1.0	20	8	43	0.0002	2LC0170-1AA	0.6
80	85	7200	–	38	–	42	48	80	80	68	30	3	1.0	30	10	63	0.0006	2LC0170-2AA	1.3
95	140	6600	–	48	–	48	60	95	76	76	35	3	1.0	30	12	73	0.0012	2LC0170-3AA	1.8
110	225	6300	–	55	–	55	70	110	86	86	40	3	1.0	34	14	83	0.0024	2LC0170-4AA	2.8
125	345	6100	–	60	–	60	82	125	100	100	50	3	1.0	36	18	103	0.005	2LC0170-5AA	4.7
140	500	5800	–	65	–	65	90	140	100	100	55	3	1.0	34	20	113	0.007	2LC0170-6AA	5.7
160	840	5100	–	70	–	70	105	160	108	108	60	4	2.0	39	20	124	0.01	2LC0170-7AA	7.8
180	1250	4500	–	80	–	80	120	180	125	125	70	4	2.0	42	20	144	0.02	2LC0170-8AA	12
200	1950	4000	–	85	–	85	130	200	140	140	80	4	2.0	47	24	164	0.04	2LC0171-0AA	17
225	2300	3600	–	90	–	90	150	225	150	150	90	4	2.0	52	18	184	0.06	2LC0171-1AA	23
250	3900	3300	46	100	46	100	170	250	165	165	100	5.5	2.5	60	18	205.5	0.11	2LC0171-2AA	30
280	5500	3000	49	110	54	110	190	280	180	180	110	5.5	2.5	65	20	225.5	0.18	2LC0171-3AA	41

Configurable variants ¹⁾

- ØD1 Without finished bore
With finished bore
- ØD2 Without finished bore
With finished bore

Notes

- Weights and mass moments of inertia apply to maximum bores.

Ordering example

- N-EUPEX B coupling, size 95
- Part 1: Bore D1 42H7 mm, keyway to DIN 6885-1 and set screw
- Part 2: Bore D2 32H7 mm, keyway to DIN 6885-1 and set screw

Article no.: 2LC0170-3AA99-0AA0 L0X+M0T

¹⁾ To identify complete item numbers specifying the available finish boring options and – if necessary – further order options, please use our configurators on flender.com.

²⁾ Version with part 40 (jumbo hub) available on request.

↗ For online configuration on flender.com, click on the item no.

TYPE B

with clamping elements

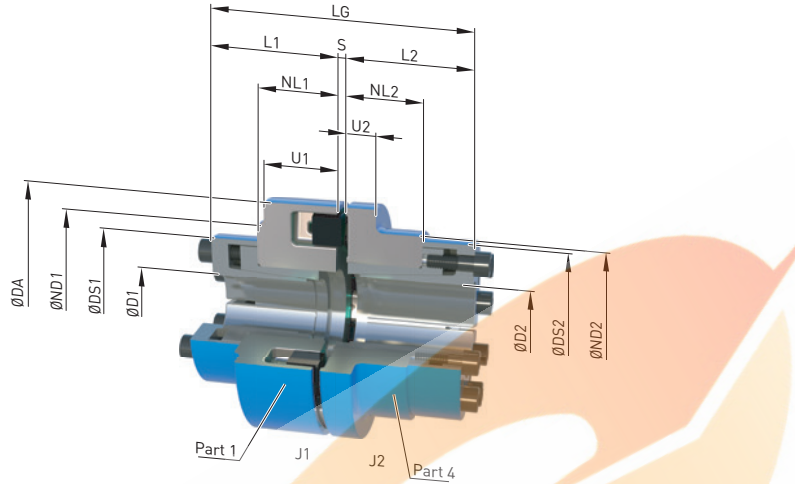

Size	Rated torque ²⁾ flexible type 80 ShoreA T_{KN} Nm	Speed n_{Kmax} rpm	Dimensions in mm														Mass moment of inertia		Article no. ¹⁾	Weight m kg
			Bore with keyway to DIN 6885-1		DA	ND1	ND2	NL1	NL2	S	ΔS +/-	DS1	DS2	L1	L2	LG	J_1 kgm ²	J_2 kgm ²		
			D1 max.	D2 max.																
80	85	7200	25	30	80	80	68	30	26	3	1.0	56	62	50	46	99	0.0007	0.0011	2LC0170-2BF	2.0
95	140	6600	30	38	95	95	76	30	31	3	1.0	62	72	50	51	104	0.0013	0.0012	2LC0170-3BF	2.7
110	225	6300	38	40	110	88	86	35	31	3	1.0	72	75	55	51	109	0.0027	0.0035	2LC0170-4BF	3.8
125	345	6100	40	48	125	125	100	35	46	3	1.0	75	87	55	71	129	0.0046	0.0062	2LC0170-5BF	5.9
140	500	5800	40	48	140	101	100	39	46	3	1.0	75	87	59	71	133	0.0067	0.0089	2LC0170-6BF	7.1
160	840	5100	55	55	160	108	108	52	52	4	2.0	98	98	77	77	158	0.013	0.014	2LC0170-7BF	10
180	1250	4500	65	65	180	125	125	52	52	4	2.0	111	111	77	77	158	0.021	0.024	2LC0170-8BF	13
200	1950	4000	70	75	200	140	140	62	62	4	2.0	119	126	93	93	190	0.039	0.047	2LC0171-0BF	19
225	2300	3600	75	75	225	150	150	63	63	4	2.0	126	126	94	94	192	0.064	0.063	2LC0171-1BF	24
250	3900	3300	85	85	250	165	165	70	70	5.5	2.5	137	137	101	101	207.5	0.11	0.10	2LC0171-2BF	32
280	5500	3000	85	85	280	180	180	77	77	5.5	2.5	137	137	108	108	221.5	0.18	0.16	2LC0171-3BF	43

Configurable variants¹⁾

- ØD1 with clamping element
- ØD2 with clamping element

Notes

- For dimensions U1 and U2, see type B on Page 7/12.
- Weights and mass moments of inertia apply to maximum bores.
- Recommended shaft tolerances h8 to m6

Ordering example

- N-EUPEX B coupling with clamping element, size 95
- Part 1: Bore D1 30 mm
recommended shaft tolerances h8 to m6
- Part 4: Bore D2 38 mm
recommended shaft tolerances h8 to m6

Article no.: 2LC0170-3BF99-0AA0 L0S+M0V

¹⁾ To identify complete item numbers specifying the available size of the clamping element and – if necessary – further order options, please use our configurators on flender.com.

²⁾ If clamping elements are used, their maximum permissible torques must be observed. The relevant information can be consulted through our configurators on flender.com.

➤ For online configuration on flender.com, click on the item no.

TYPE DK

for large misalignment with simple installation and removal

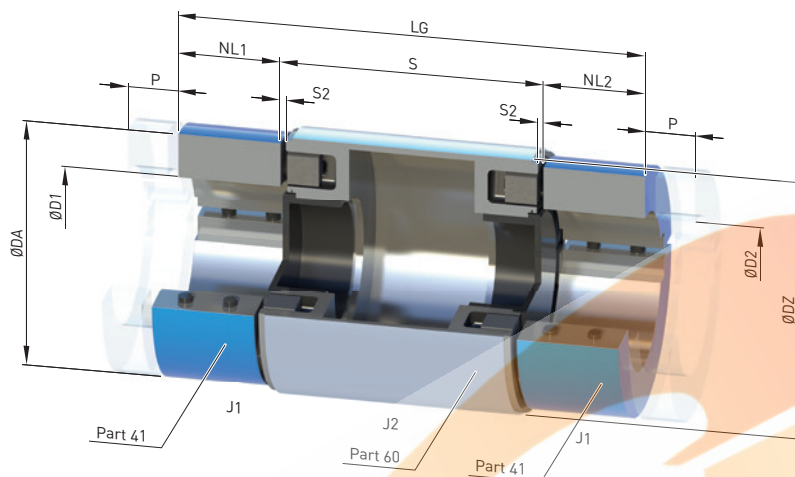

Size	Rated torque flexible type HP T_{KN}	Speed n_{Kmax}	Dimensions in mm											Mass moment of inertia		Article no. ¹⁾	Weight m	
			Bore with keyway to DIN 6885-1		DZ	NL1/NL2	Shaft distances S ²⁾		P	LG	J_1	J_2						
			D1/D2	DA			Preferred dimension	Available standard dimensions					ΔS	S2				
	Nm	rpm	min.	max.														kg
68	48	5500	20	40	68	70	30	100		1	2	15	160	0.0004	0.0003	2LC0170-1BA	1.66	
80	85	5300	25	48	80	86	34	100	140	1	2	16	168	0.001	0.001	2LC0170-2BA	2.64	
95	140	5100	25	60	95	100	40	100	140	1	2	18	180	0.002	0.002	2LC0170-3BA	4.0	
110	225	4800	30	70	110	120	45	100	140, 180	1	2	21	190	0.004	0.005	2LC0170-4BA	6.0	
125	345	4600	30	82	125	130	50	140	100, 180, 200	1	2.5	24	240	0.008	0.007	2LC0170-5BA	8.2	
140	500	4400	40	90	140	150	54	140	100, 180, 200, 250	1	2.5	26	248	0.013	0.014	2LC0170-6BA	11.8	
160	840	4000	40	105	160	170	70	140	180, 200, 250	1.5	3	30	280	0.030	0.024	2LC0170-7BA	18.3	
180	1250	3700	40	120	180	190	75	180	140, 200, 250	1.5	3	32	330	0.051	0.043	2LC0170-8BA	24.8	
200	1950	3400	45	130	200	210	80	180	140, 200, 250	1.5	3.5	35	340	0.085	0.069	2LC0171-0BA	33.7	
225	2300	3000	45	150	225	240	90	180	200, 250	1.5	3.5	39	360	0.152	0.123	2LC0171-1BA	46.9	

Configurable variants¹⁾

- ØD1 With finished bore
- ØD2 With finished bore

Notes

- The total length, weight and mass moments of inertia apply to maximal bores and shaft distances according to the preferred dimension.
- Recommended shaft tolerances $j6$ to $p6$
- A combination of part 60 with other cam parts as part 41 is not permitted.

Ordering example

- N-EUPEX DK coupling, size 95, S = 100 mm
- Part 41-1: Bore D1 42 mm, with keyway as per DIN 6885-1, recommended shaft tolerances $j6$ to $p6$
- Part 41-2: Bore D1 32 mm, with keyway as per DIN 6885-1, recommended shaft tolerances $j6$ to $p6$

Article no.: 2LC0170-3BA99-0AA0 L0X+M0T

¹⁾ To identify complete item numbers specifying the available finish boring options and – if necessary – further order options, please use our configurators on flender.com.

²⁾ Special lengths on request.

↗ For online configuration on flender.com, click on the item no.

TYPE DKS

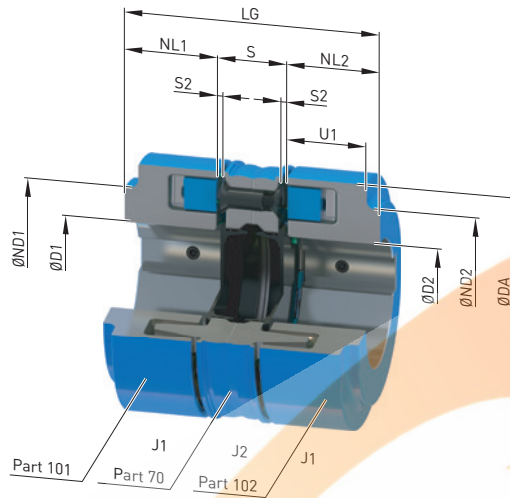

Size	Rated torque flexible type HP T_{KN} Nm	Speed n_{Kmax} rpm	Dimensions in mm										Mass moment of inertia		Article no. ¹⁾	Weight m kg
			Bore with keyway to DIN 6885-1 D1/D2		DA	ND1/ ND2	NL1/ NL2	S	ΔS +/-	S2	U1	LG	J_1 kgm ²	J_2 kgm ²		
min.	max.															
80	85	5300	-	38	80	80	30	26	1.0	2	30	86	0.0006	0.0007	2LC0170-2BD	1.8
95	140	5100	-	48	95	76	35	26	1.0	2	30	96	0.0012	0.0013	2LC0170-3BD	2.6
110	225	4800	-	55	110	86	40	28	1.0	2	34	108	0.0024	0.0025	2LC0170-4BD	4.0
125	345	4600	-	60	125	100	50	29	1.0	2.5	36	129	0.005	0.004	2LC0170-5BD	5.9
140	500	4400	-	65	140	100	55	35	1.0	2.5	34	145	0.006	0.008	2LC0170-6BD	7.6
160	840	4000	-	70	160	108	60	36	1.5	3	39	156	0.012	0.014	2LC0170-7BD	11
180	1250	3700	-	80	180	125	70	36	1.5	3	42	176	0.021	0.023	2LC0170-8BD	15
200	1950	3400	-	85	200	140	80	41	1.5	3.5	47	201	0.038	0.040	2LC0171-0BD	22
225	2300	3000	-	90	225	150	90	41	1.5	3.5	52	221	0.065	0.070	2LC0171-1BD	31
250	3900	2600	46	100	250	165	100	54	2.0	4	60	254	0.11	0.14	2LC0171-2BD	44
280	5500	2400	49	110	280	180	110	54	2.0	4	65	274	0.19	0.21	2LC0171-3BD	58

Configurable variants ¹⁾

- ØD1 Without finished bore
With finished bore
- ØD2 Without finished bore
With finished bore

Notes

- The total length, weight and mass moments of inertia apply to maximal bores and shaft distances according to the preferred dimension.

Ordering example

- N-EUPEX DKS coupling, size 95
- Part 1-01: Bore D1 42H7 mm, with keyway as per DIN 6885-1 and set screw
- Part 1-02: Bore D2 32H7 mm, with keyway as per DIN 6885-1 and set screw

Article no.: 2LC0170-3BD99-0AA0 L0X+M0T

¹⁾ To identify complete item numbers specifying the available finish boring options and – if necessary – further order options, please use our configurators on fletcher.com.

↗ For online configuration on fletcher.com, click on the item no.

TYPE H

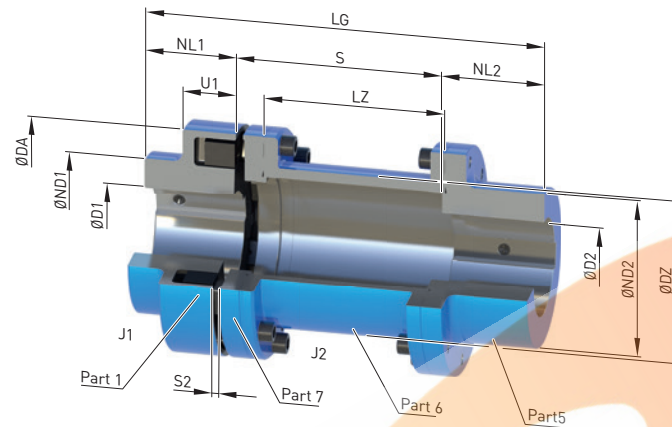

Size	Rated torque flexible type 80 ShoreA T_{KN} Nm	Speed n_{Kmax} rpm	Dimensions in mm Bore with keyway to DIN 6885-1														Mass moment of inertia		Article no. ¹⁾	Weight m kg			
			D1		D2		DA	ND1 ²⁾	ND2	NL1	NL2	S	S2	LZ	DZ	LG	J_1 kgm ²	J_2 kgm ²					
			min.	max.	min.	max.																	
80	85	7200	-	38	-	38 ³⁾	80	80	55	30	45	100	5	87	51	175	0.0006	0.001	2LC0170-2AG	2.4			
												140		127		215		0.001		2LC0170-2AG	2.5		
95	140	6600	-	48	-	48 ³⁾	95	76	70	35	45	100	5	87	63	180	0.0009	0.003	2LC0170-3AG	3.3			
												140		127		220		0.003		2LC0170-3AG	3.6		
110	225	6300	-	55	-	55 ³⁾	110	86	80	40	50	100	85	73	190	0.003	0.005	2LC0170-4AG	4.8				
											50		140		5		125		73	230	0.006	2LC0170-4AG	5.0
125	345	6100	-	60	-	60 ³⁾	125	100	90	50	60	180	5	165	85	240	0.005	0.01	2LC0170-5AG	7.4			
											60		180	5		165		85		290	0.011	2LC0170-5AG	7.8
											70		200			185				320	0.012	2LC0170-5AG	8.1
											80		250			235				380	0.012	2LC0170-5AG	8.6
											65		100			82				220	0.018	2LC0170-6AG	9.6
											65		140			122				260	0.019	2LC0170-6AG	10.1
140	500	5800	-	65	-	65 ³⁾	140	100	100	55	65	180	5	162	91	300	0.007	0.02	2LC0170-6AG	10.6			
											65		200			182				320	0.021	2LC0170-6AG	10.9
											80		250			232				385	0.022	2LC0170-6AG	11.5

Configurable variants ¹⁾

- ØD1 Without finished bore
With finished bore
- ØD2 Without finished bore
With finished bore

¹⁾ To identify complete item numbers specifying the available finish boring options and – if necessary – further order options, please use our configurators on flender.com.

²⁾ The hub diameter HD1 can be smaller for small bores.

³⁾ For bore diameters greater than the following values, the feather key must be at least 3 mm behind the shaft end. Gr. 80 D2 > 32 mm; Gr. 95 D2 > 42 mm; Gr. 110 D2 > 50 mm; Gr. 125 D2 > 59 mm; Gr. 140 D2 > 64 mm.

➤ For online configuration on flender.com, click on the item no.

Size	Rated torque flexible type 80 ShoreA T_{KN} Nm	Speed n_{Kmax} rpm	Dimensions in mm Bore with keyway to DIN 6885-1													Mass moment of inertia		Article no. ¹⁾	Weight m kg												
			D1		D2		DA	ND1 ²⁾	ND2	NL1	NL2	S	S2	LZ	DZ	LG	J_1 kgm ²			J_2 kgm ²											
			min.	max.	min.	max.																									
160	840	5100	-	70	-	70	160	108	108	60					70	100	81.5	230	0.03	2LC0170-7AG	12.5										
															70	140	121.5	270	0.032	2LC0170-7AG	13										
															70	180	161.5	111	310	0.013	0.034	2LC0170-7AG	14								
															70	200	181.5	330	0.035	2LC0170-7AG	14										
180	1250	4500	-	80	-	80	180	125	125	70	80																				
																							80	250	231.5	390	0.037	2LC0170-7AG	15		
																							140	121.5	290	0.053	2LC0170-8AG	18			
																							180	161.5	330	0.057	2LC0170-8AG	19			
200	1950	4000	-	85	-	90	200	140	140	80	90																				
																							200	250	231.5	400	0.064	2LC0170-8AG	21		
																							140	118.5	310	0.094	2LC0171-0AG	25			
																							180	158.5	350	0.099	2LC0171-0AG	26			
225	2300	3600	-	90	-	95	225	150	150	90	100																				
																							200	250	228.5	420	0.109	2LC0171-0AG	28		
																							140	118.5	330	0.157	2LC0171-1AG	33			
																							180	158.5	370	0.16	2LC0171-1AG	34			
250	3900	3300	46	100	46	100	250	165	165	100	110																				
																							200	8	172.5	185	410	0.12	0.28	2LC0171-2AG	50
																							250	222.5	460	0.3	2LC0171-2AG	52			
																							280	222.5	215	480	0.20	0.51	2LC0171-3AG	67	
315	7100	2600	49	120	51	140	315	200	200	125	140	250	8	222.5	246	515	0.35	0.85	2LC0171-4AG	96											
350	10800	2400	61	140	51	160	350	230	230	140	150	250	8	220.5	272	540	0.61	1.4	2LC0171-5AG	120											
400	14000	2000	66	150	51	180	400	250	250	160	180	250	8	185.5	311	590	1.1	2.8	2LC0171-6AG	190											
440	19000	1900	80	160	51	190	440	265	265	180	180	250	10	182	354	610	1.7	4.0	2LC0171-7AG	219											

Configurable variants¹⁾

- ØD1 Without finished bore
With finished bore
- ØD2 Without finished bore
With finished bore

Notes

- For dimension U1, see type A on page Page 7/11.
- During assembly, the gap dimension S2 must not exceed the permissible tolerance of +1 mm.
- Weights and mass moments of inertia apply to maximum bores.

Ordering example

- N-EUPEX H coupling, size 160, S = 200 mm
- Part 1: Bore D1 60H7 mm, keyway to DIN 6885-1 and set screw
- Part 2: Bore D2 55H7 mm, keyway to DIN 6885-1 and set screw

Article no.: 2LC0170-7AG99-0AD0 L1E+M1D

¹⁾ To identify complete item numbers specifying the available finish boring options and – if necessary – further order options, please use our configurators on flender.com.

²⁾ The hub diameter HD1 can be smaller for small bores

↗ For online configuration on flender.com, click on the item no.

TYPE D

for easy elastomer flexible replacement

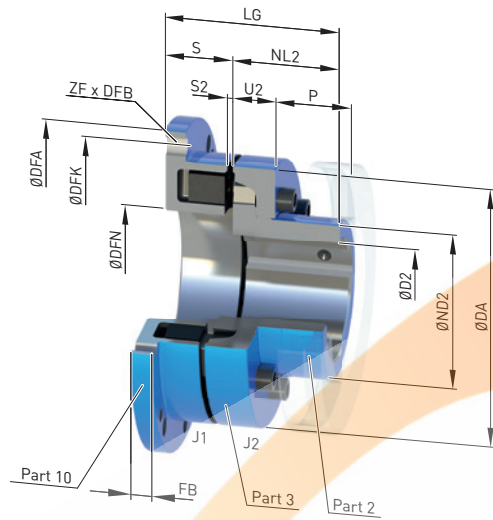

Size	Rated torque flexible type 80 ShoreA T_{KN} Nm	Speed n_{Kmax} rpm	Dimensions in mm										Flange connection dimensions						Mass moment of inertia		Article no. ¹⁾	Weight m kg
			Bore with keyway to DIN 6885-1		DA	ND2	NL2	S	ΔS +/-	S2	LG	DFA h8	DFN H7	DFK	FB	ZF	DFB	J_1 kgm ²	J_2 kgm ²			
110	225	6300	-	45	110	60.5	40	30	1.0	3	70	144	62	128	10	6	$\frac{9}{M8}$	0.0033	0.002	2LC0170-4AD1 2LC0170-4AD2	2.6	
125	345	6000	-	55	125	73.5	50	34	1.0	3	84	158	75	142	10	6	$\frac{9}{M8}$	0.005	0.004	2LC0170-5AD1 2LC0170-5AD2	3.5	
140	500	5300	-	60	140	80.5	55	37	1.0	3	92	180	82	160	13	6	$\frac{11}{M10}$	0.010	0.007	2LC0170-6AD1 2LC0170-6AD2	5.4	
160	840	4800	-	70	160	93.5	60	43	2.0	4	103	200	95	180	13	7	$\frac{11}{M10}$	0.016	0.013	2LC0170-7AD1 2LC0170-7AD2	7.1	
180	1250	4300	-	80	180	106	70	46	2.0	4	116	220	110	200	13	8	$\frac{11}{M10}$	0.025	0.023	2LC0170-8AD1 2LC0170-8AD2	9.5	
200	1950	3900	-	90	200	119	80	51	2.0	4	131	248	120	224	16	8	$\frac{14}{M12}$	0.049	0.04	2LC0171-0AD1 2LC0171-0AD2	14	
225	2300	3600	-	100	225	135	90	56	2.0	4	146	274	135	250	16	8	$\frac{14}{M12}$	0.076	0.07	2LC0171-1AD1 2LC0171-1AD2	19	
250	3900	3000	-	115	250	153	100	65.5	2.5	5.5	165.5	314	150	282	20	8	$\frac{18}{M16}$	0.15	0.13	2LC0171-2AD1 2LC0171-2AD2	28	
280	5500	3000	54	125	280	168	110	70.5	2.5	5.5	180.5	344	170	312	20	8	$\frac{18}{M16}$	0.23	0.2	2LC0171-3AD1 2LC0171-3AD2	35	

Configurable variants ¹⁾

- ØD2 Without finished bore
With finished bore

¹⁾ To identify complete item numbers specifying the available finish boring options and – if necessary – further order options, please use our configurators on flender.com.

↗ For online configuration on flender.com, click on the item no.

Size	Rated torque flexible type 80 ShoreA T_{KN} Nm	Speed n_{Kmax} rpm	Dimensions in mm										Flange connection dimensions						Mass moment of inertia		Article no. ¹⁾	Weight m kg
			Bore with keyway to DIN 6885-1 D2 min. max.		DA	ND2	NL2	S	ΔS +/-	S2	LG	DFA h8	DFN H7	DFK	FB	ZF	DFB	J_1 kgm ²	J_2 kgm ²			
315	7100	2500	45	145	315	196	125	75.5	2.5	5.5	200.5	380	200	348	22	9	18	0.4	0.37	2LC0171-4AD1	48	
																	M16			2LC0171-4AD2		
350	10800	2200	60	165	350	226	140	79.5	2.5	5.5	219.5	430	225	390	25	9	22	0.7	0.64	2LC0171-5AD1	68	
																	M20			2LC0171-5AD2		
400	14000	2000	65	180	400	246	160	83.5	2.5	5.5	243.5	480	265	440	25	10	22	1.1	1.1	2LC0171-6AD1	89	
																	M20			2LC0171-6AD2		
440	19000	1800	80	190	440	261	180	93.5	2.5	7.5	273.5	520	295	480	25	10	22	1.6	1.7	2LC0171-7AD1	117	
																	M20			2LC0171-7AD2		
480	25100	1800	90	215	480	296	190	97.5	2.5	7.5	287.5	575	325	528	30	10	26	2.6	2.7	2LC0171-8AD1	149	
																	M24			2LC0171-8AD2		
520	32400	1500	100	225	520	310	210	109.5	2.5	7.5	319.5	615	355	568	30	10	26	3.6	3.8	2LC0172-0AD1	182	
																	M24			2LC0172-0AD2		

Configurable variants ¹⁾

- $\emptyset D2$ Without finished bore
With finished bore

Notes

- For dimensions U2 and P, see type A on page Page 7/11.
- Weights and mass moments of inertia apply to maximum bores.

Ordering example

- N-EUPEX D coupling, size 125
- Part 10: with through bores
- Part 2: Bore D2 38H7 mm, with keyway to DIN 6885-1 and set screw

Article no.: 2LC0170-5AD19-0AA0 M0V

¹⁾ To identify complete item numbers specifying the available finish boring options and – if necessary – further order options, please use our configurators on flender.com.

➤ For online configuration on flender.com, click on the item no.

TYPE E

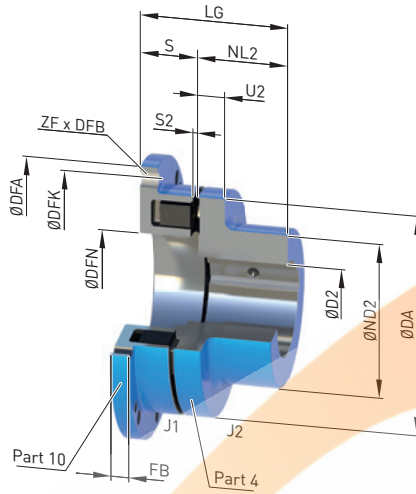

Size	Rated torque flexible type 80 ShoreA T_{KN} Nm	Speed n_{Kmax} rpm	Dimensions in mm														Mass moment of inertia		Article no. ¹⁾	Weight m kg	
			Bore with keyway to DIN 6885-1		Flange connection dimensions										J_1 kgm ²	J_2 kgm ²					
			D2 min.	D2 max.	DA	ND2	NL2	S	ΔS +/-	S2	LG	DFA h8	DFN H7	DFK	FB	ZF	DFB				
68	48	8400	-	30	68	50	20	23	1.0	3	43	90	34	80	7	6	5.5 M5	0.0004	0.0002	2LC0170-1AC1 2LC0170-1AC2	0.7
80	85	7200	-	42	80	68	30	24	1.0	3	54	106	42	94	8	6	6.6 M6	0.0008	0.0006	2LC0170-2AC1 2LC0170-2AC2	1.2
95	140	6600	-	48	95	76	35	27	1.0	3	62	120	52	108	8	6	6.6 M6	0.0013	0.0012	2LC0170-3AC1 2LC0170-3AC2	1.7
110	225	6300	-	55	110	86	40	30	1.0	3	70	144	62	128	10	6	9 M8	0.0033	0.0024	2LC0170-4AC1 2LC0170-4AC2	2.6
125	345	6000	-	60	125	100	50	34	1.0	3	84	158	75	142	10	6	9 M8	0.005	0.005	2LC0170-5AC1 2LC0170-5AC2	4.0
140	500	5300	-	65	140	100	55	37	1.0	3	92	180	82	160	13	6	11 M10	0.010	0.007	2LC0170-6AC1 2LC0170-6AC2	5.5
160	840	4800	-	70	160	108	60	43	2.0	4	103	200	95	180	13	7	11 M10	0.016	0.01	2LC0170-7AC1 2LC0170-7AC2	7.1

Configurable variants ¹⁾

- ØD2 Without finished bore
With finished bore

¹⁾ To identify complete item numbers specifying the available finish boring options and – if necessary – further order options, please use our configurators on flender.com.

↗ For online configuration on flender.com, click on the item no.

Size	Rated torque flexible type 80 ShoreA T_{KN} Nm	Speed n_{Kmax} rpm	Dimensions in mm											Flange connection dimensions					Mass moment of inertia		Article no. ¹⁾	Weight m kg
			Bore with keyway to DIN 6885-1		DA	ND2	NL2	S	ΔS +/-	S2	LG	DFA h8	DFN H7	DFK	FB	ZF	DFB	J_1 kgm ²	J_2 kgm ²			
			D2 min.	max.																		
180	1250	4300	-	80	180	125	70	46	2.0	4	116	220	110	200	13	8	$\frac{11}{M10}$	0.025	0.02	2LC0170-8AC1 2LC0170-8AC2	10	
200	1950	3900	-	85	200	140	80	51	2.0	4	131	248	120	224	16	8	$\frac{14}{M12}$	0.049	0.04	2LC0171-0AC1 2LC0171-0AC2	15	
225	2300	3600	-	90	225	150	90	56	2.0	4	146	274	135	250	16	8	$\frac{14}{M12}$	0.076	0.06	2LC0171-1AC1 2LC0171-1AC2	19	
250	3900	3000	46	100	250	165	100	65.5	2.5	5.5	165.5	314	150	282	20	8	$\frac{18}{M16}$	0.15	0.11	2LC0171-2AC1 2LC0171-2AC2	26	
280	5500	3000	54	110	280	180	110	70.5	2.5	5.5	180.5	344	170	312	20	8	$\frac{18}{M16}$	0.23	0.18	2LC0171-3AC1 2LC0171-3AC2	34	

Configurable variants ¹⁾

- $\emptyset D2$ Without finished bore
With finished bore

Notes

- For dimension U2, see type B on page Page 7/12.
- Weights and mass moments of inertia apply to maximum bores.

Ordering example

- N-EUPEX E coupling, size 125
- Part 10: with through bores
- Part 4: Bore D2 38H7 mm, with keyway to DIN 6885-1 and set screw

Article no.: 2LC0170-5AC19-0AA0 M0V

¹⁾ To identify complete item numbers specifying the available finish boring options and – if necessary – further order options, please use our configurators on flender.com.

➤ For online configuration on flender.com, click on the item no.

TYPE P

with brake drum

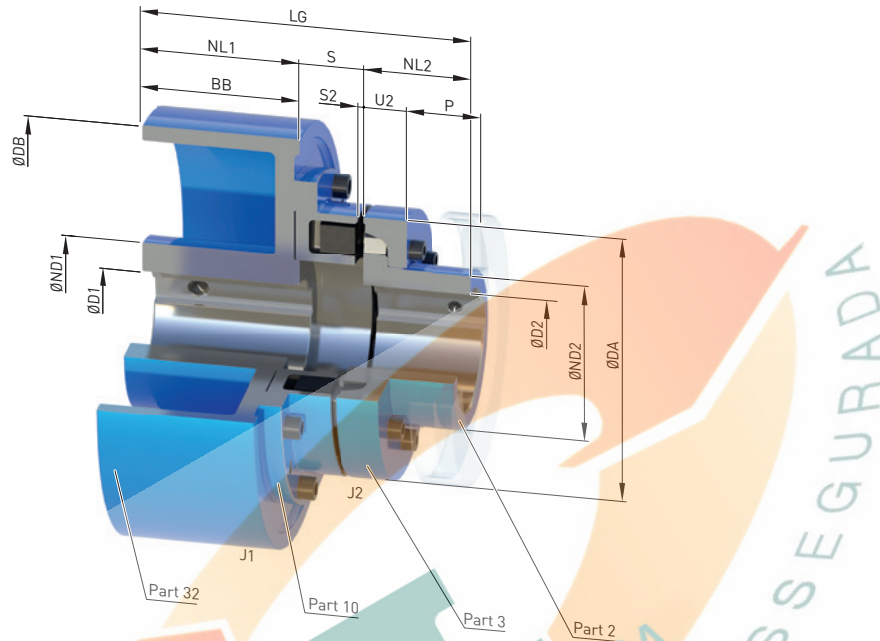

Size	Rated torque flexible type 80 ShoreA T_{KN} Nm	Speed n_{Kmax} rpm	Dimensions in mm											Mass moment of inertia		Article no. ¹⁾	Weight m kg				
			Bore with keyway to DIN 6885-1		DA	ND1	ND2	NL1/BB	NL2	S	ΔS +/-	S2	DB	U2	LG			J_1 kgm ²	J_2 kgm ²		
D1	D2	min.	max.	min.												max.					
125	345	4800	-	55	-	55	125	84	73.5	75	50	31	1.0	3	200	23	156	0.043	0.004	2LC0170-5AF	11
140	500	3800	-	60	-	60	140	128	80.5	95	55	34	1.0	3	250	28	184	0.13	0.007	2LC0170-6AF	21
160	840	3800	-	70	-	70	160	128	93.5	95	60	40	2.0	4	250	28	195	0.14	0.013	2LC0170-7AF	21
180	1250	3800	-	80	-	80	180	128	106	95	70	41	2.0	4	250	30	206	0.16	0.023	2LC0170-8AF	27
		3000	-	80	-	80	128	118	118	70	43	48	315	30	231	0.35	2LC0170-8AF	34			
		3000	-	80	-	80	128	118	118	70	48	48	315	30	246	0.37	2LC0171-0AF	39			
200	1950	2400	-	90	-	90	200	160	119	150	80	48	2.0	4	400	32	278	1.1	0.04	2LC0171-0AF	59
		1900	-	110	-	110	175	190	190	80	48	51	500	32	318	2.8	2LC0171-0AF	97			
		3000	-	80	-	80	128	118	118	70	48	48	315	30	259	0.39	2LC0171-1AF	46			
225	2300	2400	-	90	-	100	225	160	135	150	90	53	2.0	4	400	38	293	1.1	0.07	2LC0171-1AF	64
		1900	38	110	-	110	175	190	190	80	53	51	500	38	333	3.1	2LC0171-1AF	103			

Configurable variants ¹⁾

- ØD1 Without finished bore
With finished bore
- ØD2 Without finished bore
With finished bore

¹⁾ To identify complete item numbers specifying the available finish boring options and – if necessary – further order options, please use our configurators on flender.com.

↗ For online configuration on flender.com, click on the item no.

Size	Rated torque flexible type 80 ShoreA T_{KN} Nm	Speed n_{Kmax} rpm	Dimensions in mm													Mass moment of inertia		Article no. ¹⁾	Weight m kg		
			Bore with keyway to DIN 6885-1			DA	ND1	ND2	NL1/BB	NL2	S	ΔS +/-	S2	DB	U2	LG	J_1 kgm ²			J_2 kgm ²	
D1	D2		min.		max.																
250	3900	2400	-	100	-	115	250	160	153	150	100	62.5	2.5	5.5	400	42	312.5	1.16	0.13	2LC0171-2AF	74
		1900	38	110	-	115	250	175	153	190	100	62.5	2.5	5.5	500	42	352.5	2.9		2LC0171-2AF	111
		2400	-	100	-	115	250	160	150	150	100	65.5	2.5	5.5	400	42	325.5	1.24		2LC0171-3AF	82
280	5500	1900	48	110	54	125	280	175	168	190	110	67.5	2.5	5.5	500	42	367.5	3.1	0.2	2LC0171-3AF	115
		1500	48	110	-	125	280	175	168	236	110	67.5	2.5	5.5	630	42	413.5	8.0		2LC0171-3AF	168
		2400	-	100	-	125	280	160	150	150	110	72.5	2.5	5.5	400	42	347.5	1.4		2LC0171-4AF	92
315	7100	1900	48	110	45	145	315	175	196	190	125	72.5	2.5	5.5	500	47	387.5	3.3	0.37	2LC0171-4AF	131
		1500	48	110	-	145	315	175	196	236	125	72.5	2.5	5.5	630	47	433.5	8.2		2LC0171-4AF	180
		1300	55	120	-	145	315	192	265	265	140	72.5	2.5	5.5	710	47	462.5	14.2		2LC0171-4AF	233
350	10800	1500	48	110	60	165	350	175	226	236	140	76.5	2.5	5.5	630	51	452.5	8.5	0.64	2LC0171-5AF	197
		1300	55	120	-	165	350	192	265	265	140	76.5	2.5	5.5	710	51	481.5	14.6		2LC0171-5AF	251

Configurable variants ¹⁾

- ØD1 Without finished bore
With finished bore
- ØD2 Without finished bore
With finished bore

Notes

- For dimension P, see type A on page Page 7/11.
- Weights and mass moments of inertia apply to maximum bores.

Ordering example

- N-EUPEX P coupling, size 200, brake drum 315 x 118 mm
- Part 32: Bore D1 55H7 mm, keyway to DIN 6885-1 P9 and set screw
- Part 4: Bore D2 60H7 mm, keyway to DIN 6885-1 and set screw
- Coupling micro-balanced G 6.3 at 1500 rpm in accordance with half parallel key standard

Article no.: 2LC0171-0AF99-0DA0-Z L1D+M1E+W02+Y95
Plain text to Y95: G=6.3;n=1500rpm

¹⁾ To identify complete item numbers specifying the available finish boring options and – if necessary – further order options, please use our configurators on flender.com.

➤ For online configuration on flender.com, click on the item no.

TYPE 0

with brake drum

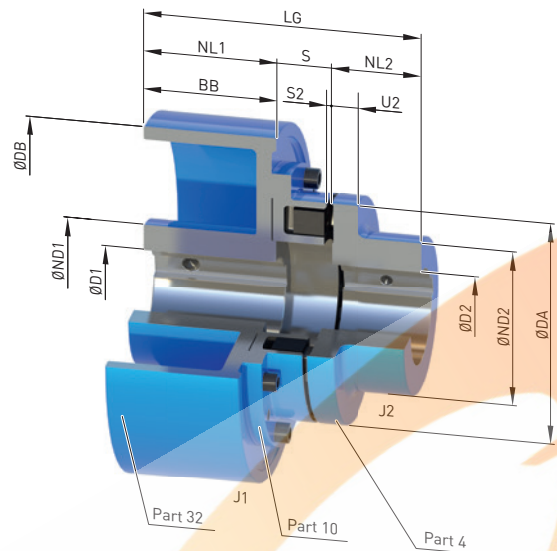

7

Size	Rated torque flexible type 80 ShoreA T_{KN} Nm	Speed n_{Kmax} rpm	Dimensions in mm Bore with keyway to DIN 6885-1														Mass moment of inertia		Article no. ¹⁾	Weight m kg			
			D1		D2		DA	ND1	ND2	NL1/BB	NL2	S	ΔS +/-	S2	DB	U2	LG	J_1 kgm ²			J_2 kgm ²		
125	345	4800	-	55	-	60	125	84	100	75	50	31	1.0	3	200	18	156	0.043	0.005	2LC0170-5AE	11		
140	500	3800	-	60	-	65	140	128	100	95	55	34	1.0	3	250	20	184	0.13	0.007	2LC0170-6AE	22		
160	840	3800	-	70	-	70	160	128	108	95	60	40	2.0	4	250	20	195	0.14	0.01	2LC0170-7AE	24		
180	1250	3800	-	80	-	80	180	128	125	95	70	41	2.0	4	250	20	206	0.16	0.02	2LC0170-8AE	28		
		3000	-	80	118	43				315		231								0.35	2LC0170-8AE	35	
200	1950	3800	-	80	-	80	200	160	140	150	80	48	2.0	4	315	24	246	0.37	0.04	2LC0171-0AE	40		
		2400	-	90	128	48						315								246	0.37	2LC0171-0AE	60
		1900	-	110	175	48						500								318	2.80	2LC0171-0AE	98

Configurable variants ¹⁾

- ØD1 Without finished bore
With finished bore
- ØD2 Without finished bore
With finished bore

¹⁾ To identify complete item numbers specifying the available finish boring options and – if necessary – further order options, please use our configurators on flender.com.

↗ For online configuration on flender.com, click on the item no.

Size	Rated torque flexible type 80 ShoreA T_{KN} Nm	Speed n_{Kmax} rpm	Dimensions in mm													Mass moment of inertia		Article no. ¹⁾	Weight m kg		
			Bore with keyway to DIN 6885-1		D1 min.	D1 max.	D2 min.	D2 max.	DA	ND1	ND2	NL1/BB	NL2	S	ΔS +/-	S2	DB			U2	LG
225	2300	3000	-	80														-	90		
		2400	-	90	-	90	225	160	150	150	90	53	2.0	4	400	18	293	1.10	0.06	2LC0171-1AE	63
		1900	38	110	-	90	225	175	190	150	90	53			500	18	333	3.10		2LC0171-1AE	102
250	3900	2400	-	100	46	100	250	160	165	150	100	62.5	2.5	5.5	400	18	312.5	1.16	0.11	2LC0171-2AE	73
		1900	38	110	46	100	250	175	190	150	100	62.5			500	18	352.5	2.90		2LC0171-2AE	108
		2400	-	100	54	110	280	160	150	150	110	65.5			400	20	325.5	1.24		2LC0171-3AE	82
280	5500	1900	48	110	54	110	280	175	180	190	110	67.5	2.5	5.5	500	20	367.5	3.10	0.18	2LC0171-3AE	115
		1500	48	110	54	110	280	175	236	190	110	67.5			630	20	413.5	8.0		2LC0171-3AE	168

Configurable variants ¹⁾

- ØD1 Without finished bore
With finished bore
- ØD2 Without finished bore
With finished bore

Notes

- Weights and mass moments of inertia apply to maximum bores.

Ordering example

- N-EUPEX O coupling, size 200, brake drum 315 x 118 mm
- Part 32: Bore D1 55H7 mm, keyway to DIN 6885-1 P9 and set screw
- Part 4: Bore D2 60H7 mm, keyway to DIN 6885-1 and set screw
- Coupling micro-balanced G 6.3 at 1500 rpm in accordance with half parallel key standard

Article no.: 2LC0171-0AE99-0DA0-Z L1D+M1E+W02+Y95
Plain text to Y95: G=6.3;n=1500rpm

¹⁾ To identify complete item numbers specifying the available finish boring options and – if necessary – further order options, please use our configurators on flender.com.

➤ For online configuration on flender.com, click on the item no.

TYPE DBDR

with brake disk

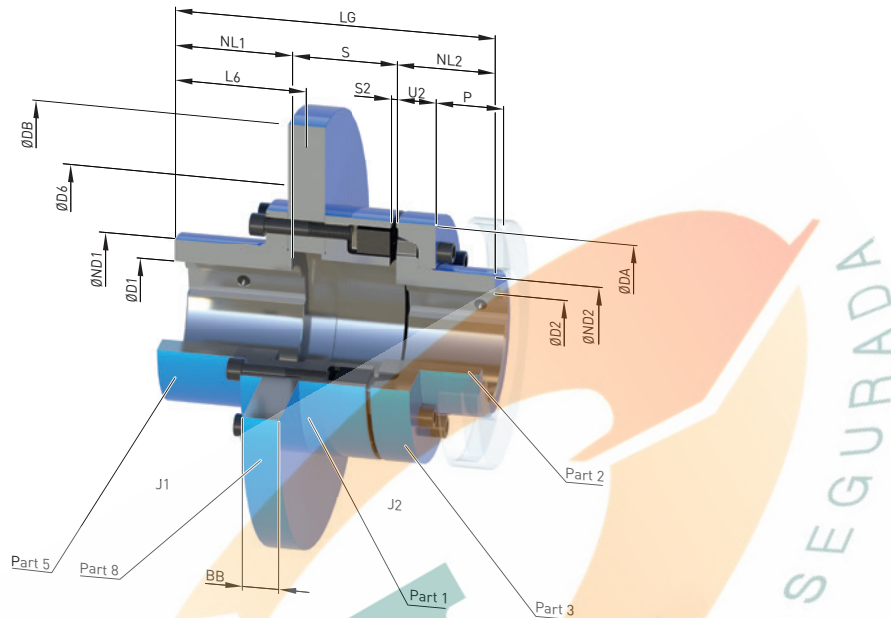

Size	Rated torque flexible type 80 ShoreA T_{KN} Nm	Dimensions in mm														Mass moment of inertia		Article no. ¹⁾	Weight m kg			
		Bore with keyway to DIN 6885-1			DA	ND1	ND2	NL1	NL2	S	ΔS +/-	S2	DB ²⁾ min.	D6 min.	BB ²⁾	L6	LG			J_1 min. kgm ²	J_2 kgm ²	
D1 max.	D2 min.	D2 max.																				
140	500	60	-	60	140	85	80.5	72	55	54.35	1.0	3	315	150	12.7	74	181.35	0.11	0.008	2LC0170-6AV	14.7	
								188	73	73					30	200	316				0.24	16.2
								90	58.35	78					30	200	326				0.26	26.9
160	840	75	-	70	160	105	93.5	90	60	62.5	2.0	4	315	170	12.7	91	208.35	0.12	0.013	2LC0170-7AV	18.5	
								188	78	78					30	200	326				0.26	20
								90	60.35	80					30	200	326				0.26	31
180	1250	90	-	80	180	125	106	90	70	64.5	2.0	4	315	190	12.7	91	220.35	0.35	0.024	2LC0170-8AV	25	
								188	80	80					30	200	338				0.57	26
								95	67.35	86					30	200	338				0.57	42
200	1950	95	-	90	200	135	119	95	80	70.5	2.0	4	355	210	12.7	97	242.35	0.32	0.04	2LC0171-0AV	32	
								188	86	86					30	200	354				0.67	35
								95	67.35	86					30	200	354				0.67	54

Configurable variants ¹⁾

- ØD1 With finished bore
- ØD2 Without finished bore
With finished bore

¹⁾ To identify complete item numbers specifying the available finish boring options and – if necessary – further order options, please use our configurators on flender.com.

²⁾ For the available DB · BB brake disk dimensions, please refer to the product configurator on flender.com.

↗ For online configuration on flender.com, click on the item no.

Size	Rated torque flexible type 80 ShoreA T_{KN} Nm	Dimensions in mm														Mass moment of inertia		Article no. ¹⁾	Weight m kg		
		Bore with keyway to DIN 6885-1			DA	ND1	ND2	NL1	NL2	S	ΔS +/-	S2	DB ²⁾ min.	D6 min.	BB ²⁾	L6	LG			J_1 min. kgm ²	J_2 kgm ²
225	2300	115	-	100	225	160	135	100	90	72.35	2.0	4	400	235	12.7	103	262.35	0.52	0.08	2LC0171-1AV	43
					100	90	74.5	15	104	264.5					0.59	46					
					188	90	90	30	200	368					1.1	71					
250	3900	120	-	115	250	170	153	105	100	83.35	+2/-3	6	450	260	12.7	107	288.35	1.6	0.12	2LC0171-2AV	56
					105	100	86.5	15	109	291.5					1.7	59					
					188	102	102	30	200	390					2.5	88					
280	5500	140	54	125	280	200	168	120	110	87.35	+2/-3	6	500	350	12.7	122	317.35	1.3	0.19	2LC0171-3AV	73
					120	110	90.5	15	124	320.5					1.5	77					
					188	106	106	30	200	404					2.7	112					
315	7100	140	45	145	315	200	196	130	125	87.35	+2/-3	6	500	350	12.7	130	342.35	2.1	0.33	2LC0171-4AV	95
					130	125	92.5	15	134	347.5					2.3	100					
					188	108	108	30	200	421					4.2	140					
350	10800	165	60	165	350	230	226	135	140	97.35	+2/-3	6	500	360	12.7	136	372.35	3.3	0.57	2LC0171-5AV	129
					135	140	101.5	15	139	376.5					3.8	134					
					188	117	117	30	200	445					6.7	184					

Configurable variants¹⁾

- ØD1 With finished bore
- ØD2 Without finished bore
With finished bore

Notes

- For dimensions U2 and P, see type A on page Page 7/11.
- Weights and mass moments of inertia apply to maximum bores.
- Maximum speed $n_{max} = 1528/DB$ (n_{max} in rpm, DB in m)
Observe maximum speed of type A.
- Other brake disk diameters DB and brake disk widths BB on request.

Ordering example

- N-EUPEX DBDR coupling, size 200, brake disk 450 x 30 mm
- Part 5: Bore D1 55H7 mm, keyway to DIN 6885-1 P9 and set screw
- Part 2: Bore D2 60H7 mm, keyway to DIN 6885-1 and set screw
- Coupling micro-balanced G 6.3 at 1500 rpm in accordance with half parallel key standard

Article no.: 2LC0171-0AV99-0GA0-Z L1D+M1E+W02+Y95
Plain text to Y95: G=6.3;n=1500rpm

¹⁾ To identify complete item numbers specifying the available finish boring options and – if necessary – further order options, please use our configurators on flender.com.

²⁾ For the available DB · BB brake disk dimensions, please refer to the product configurator on flender.com.

↗ For online configuration on flender.com, click on the item no.

TYPE ABD

with brake disk

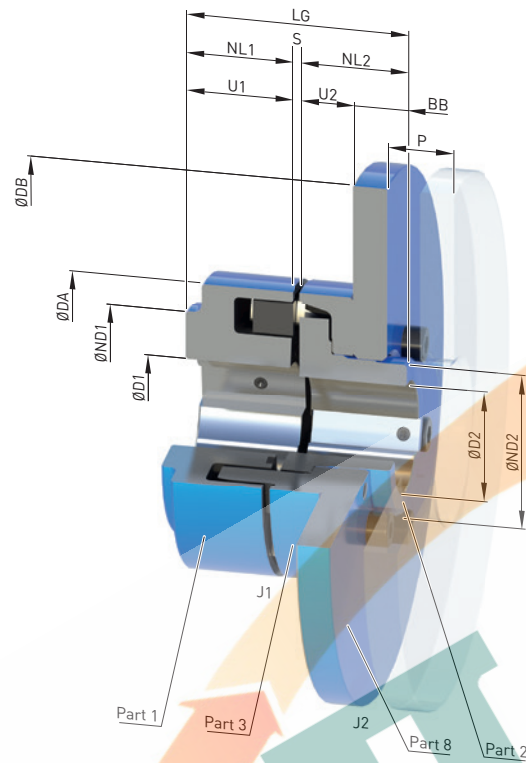

Size	Rated torque flexible type 80 ShoreA T_{KN} Nm	Speed n_{Kmax} rpm	Dimensions in mm Bore with keyway to DIN 6885-1													Mass moment of inertia		Article no. ¹⁾	Weight m kg			
			D1		D2		DA	ND1 ²⁾	ND2	NL1/NL2	S	ΔS +/-	U1	U2	P	DB ³⁾	BB ³⁾			LG	J_1 kgm ²	J_2 kgm ²
			min.	max.	min.	max.									min.							
140	500	5500	-	65	-	60	140	100	80.5	55	3	1.0	34	28	43	315	12.7	113	0.007	0.10	2LC0170-6BB	12.8
160	840	5100	-	70	-	70	160	108	93.5	60	4	2.0	39	28	47	315	12.7	124	0.013	0.11	2LC0170-7BB	14.8
180	1250	4500	-	80	-	80	180	125	106	70	4	2.0	42	30	50	355	12.7	144	0.023	0.18	2LC0170-8BB	20
200	1950	4000	-	85	-	90	200	140	119	80	4	2.0	47	32	53	400	12.7	164	0.04	0.29	2LC0171-0BB	27
225	2300	3600	-	90	-	100	225	150	135	90	4	2.0	52	38	61	450	30	184	0.07	1.0	2LC0171-1BB	57
250	3900	3300	46	100	-	115	250	165	153	100	5.5	2.5	60	42	69	500	30	205.5	0.13	1.6	2LC0171-2BB	73
280	5500	3000	49	110	54	125	280	180	168	110	5.5	2.5	65	42	73	560	30	225.5	0.20	2.5	2LC0171-3BB	94
315	7100	2600	49	120	45	145	315	200	196	125	5.5	2.5	70	47	78	630	30	255.5	0.37	4.0	2LC0171-4BB	126
350	10800	2400	61	140	60	165	350	230	226	140	5.5	2.5	74	51	83	710	30	285.5	0.64	6.5	2LC0171-5BB	167

Configurable variants ¹⁾

- ØD1 Without finished bore
With finished bore
- ØD2 Without finished bore
With finished bore

Notes

- Weights and mass moments of inertia apply to maximum bores.

Ordering example

- N-EUPEX ABD coupling, size 200, brake disk 400 x 12.7 mm
- Part 1: Bore D1 65H7 mm, keyway to DIN 6885-1 and set screw
- Part 2: Bore D2 50H7 mm, keyway to DIN 6885-1 P9 and set screw
- Coupling micro-balanced G 6.3 at 1500 rpm in accordance with half parallel key standard

Article no.: 2LC0171-0BB99-2FA0-Z L1F+M1C+W02+Y95
Plain text to Y95: G=6.3;n=1500rpm

¹⁾ To identify complete item numbers specifying the available finish boring options and – if necessary – further order options, please use our configurators on flender.com.

²⁾ The hub diameter HD1 can be smaller for small bores.

³⁾ For the available DB · BB brake disk dimensions, please refer to the product configurator on flender.com.

↗ For online configuration on flender.com, click on the item no.

TYPE ERN

with slip unit

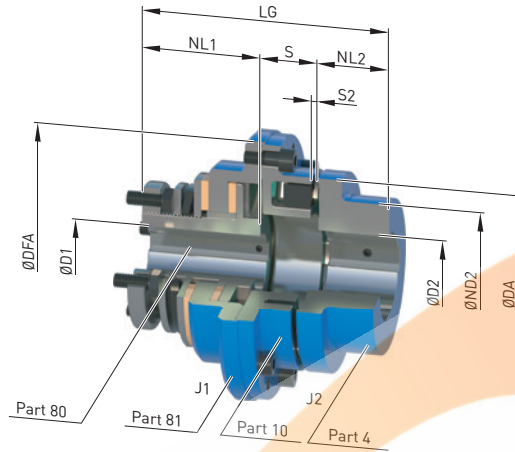

Size	Rated torque flexible type 80 ShoreA T_{KN} Nm	Slip torque		Speed n_{Kmax} rpm	Dimensions in mm													Mass moment of inertia		Article no. ¹⁾	Weight m kg
		T_{R1} Nm	T_{R2} Nm		D1 max.	D2 max.	DA	ND2	NL1	NL2	S	ΔS +/-	S2	DFA	LG	J_1 kgm ²	J_2 kgm ²				
80	85	130	240	3800	30	42	80	68	55	30	25	1.0	3	109	110	0.0039	0.0006	2LC0170-2BE	3.3		
95	140	190	340	3600	35	48	95	76	66	35	28	1.0	3	123	129	0.007	0.0012	2LC0170-3BE	4.8		
110	225	190	340	3600	35	55	110	86	66	40	31	1.0	3	147	137	0.010	0.0024	2LC0170-4BE	5.8		
125	345	350	650	3000	45	60	125	100	77	50	35	1.0	3	161	162	0.017	0.005	2LC0170-5BE	8.9		
140	500	650	1200	2500	60	65	140	100	86	55	38	1.0	3	183	179	0.035	0.008	2LC0170-5BE	13		
160	840	650	1200	2500	60	70	160	108	86	60	44	2.0	4	204	190	0.050	0.013	2LC0170-7BE	15		
180	1250	1000	1800	2100	65	80	180	125	93	70	47	2.0	4	224	210	0.084	0.025	2LC0170-8BE	22		
200	1950	2200	4000	1800	80	85	200	140	105	80	52	2.0	4	252	237	0.16	0.044	2LC0171-0BE	32		
225	2300	2200	4000	1800	80	90	225	150	105	90	57	2.0	4	278	252	0.22	0.064	2LC0171-1BE	37		
250	3900	3800	6800	1500	90	100	250	165	120	100	66.5	2.5	5.5	319	286.5	0.51	0.10	2LC0171-2BE	60		
280	5500	5500	10000	1500	120	110	280	180	120	110	71.5	2.5	5.5	349	301.5	0.77	0.17	2LC0171-3BE	74		

Configurable variants ¹⁾

- ØD1 With finished bore
- ØD2 Without finished bore
With finished bore

Notes

- Weights and mass moments of inertia apply to maximum bores.

Ordering example

- N-EUPEX ERN coupling, size 200
Slip torque $T_R = 4000$ Nm
- Part 1: Bore D1 65H7 mm, keyway to DIN 6885-1 and set screw
- Part 2: Bore D2 50H7 mm, keyway to DIN 6885-1 and set screw

Article no.: 2LC0171-0BE99-2AA0 L1F+M1C

¹⁾ To identify complete item numbers specifying the available finish boring options and – if necessary – further order options, please use our configurators on flender.com.

↗ For online configuration on flender.com, click on the item no.



GENERAL

Technical specifications, N-EUPEX DS series

Power ratings of the N-EUPEX DS series						
Size	Rated torque	Maximum torque	Torsional stiffness at 50 % capacity utilization ¹⁾	Assembly	Permitted shaft misalignment at speed ³⁾ $n = 1500$ rpm	
	T_{KN} Nm	T_{Kmax} Nm	C_{Tdyn} kNm/rad	Gap dimension ²⁾ ΔS mm	Radial ΔK_r mm	Angle ΔK_w °
66	19	38	0.73	1.0	0.2	0.15
76	34	68	1.36	1.0	0.2	0.15
88	60	120	2.62	1.0	0.2	0.12
103	100	200	4.00	1.0	0.2	0.12
118	160	320	6.30	1.0	0.2	0.10
135	240	480	10.5	1.0	0.25	0.10
152	360	720	13.6	1.0	0.25	0.10
172	560	1120	27.2	2.0	0.3	0.10
194	880	1760	47.0	2.0	0.3	0.10
218	1340	2680	70.0	2.0	0.3	0.09
245	2000	4000	106	2.0	0.35	0.09
272	2800	5600	149	2.5	0.35	0.08
305	3900	7800	214	2.5	0.4	0.08
340	5500	11000	350	2.5	0.4	0.08
380	7700	15400	480	2.5	0.5	0.08
430	10300	20600	730	2.5	0.5	0.08
472	13500	27000	990	2.5	0.6	0.08
514	16600	33200	1270	2.5	0.6	0.07
556	21200	42400	1540	2.5	0.65	0.07

For coupling fatigue torque:
 $T_{KW} = 0,15 \cdot T_{KN}$, where $T_N > T_W$ must be adhered to.

Note

For fitting, the maximum gap dimension of $S_{max.} = S + \Delta S$ and the minimum gap dimension of $S_{min.} = S - \Delta S$ are permitted.

¹⁾ The correction factors for torsion spring stiffness and permitted shaft misalignment correspond to the specifications for the puncture-proof types Page 7/9

²⁾ Does not apply to type HDS.

³⁾ The maximum speed for the respective type must be noted. For additional information on the allowable shaft misalignment, please refer to the operating instructions.

TYPE ADS

for easy elastomer flexible replacement

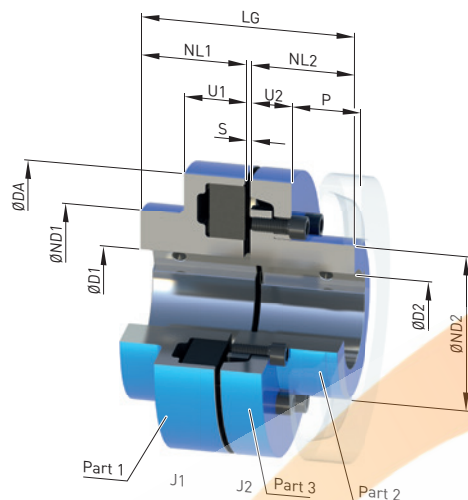

Size	Rated torque T_{KN} Nm	Speed n_{Kmax} rpm	Dimensions in mm													Mass moment of inertia J_1/J_2 kgm ²	Article no. ¹⁾	Weight m kg
			Bore with keyway to DIN 6885-1		DA	ND1	ND2	NL1/NL2	S	U1	U2	P	LG					
			D1	D2														
min.	max.	min.	max.															
118	160	5300	-	50	-	45	118	86	60.5	40	3	34	20	33	83	0.003	2LC0110-4AB	2.8
135	240	5100	-	60	-	55	135	100	73.5	50	3	36	23	38	103	0.005	2LC0110-5AB	4.3
152	360	4900	-	65	-	60	152	108	80.5	55	3	36	28	43	113	0.008	2LC0110-6AB	5.9
172	560	4250	-	70	-	70	172	118	93.5	60	4	41	28	47	124	0.014	2LC0110-7AB	8.2
194	880	3800	-	80	-	80	194	135	106	70	4	44	30	50	144	0.025	2LC0110-8AB	12
218	1340	3400	-	85	-	90	218	150	119	80	4	47	32	53	164	0.05	2LC0111-0AB	17
245	2000	3000	-	90	-	100	245	150	135	90	4	52	38	61	184	0.08	2LC0111-1AB	23
272	2800	2750	46	100	-	115	272	165	153	100	5.5	60	42	69	205.5	0.14	2LC0111-2AB	32
305	3900	2450	49	110	54	125	305	180	168	110	5.5	65	42	73	225.5	0.22	2LC0111-3AB	43
340	5500	2150	49	120	45	145	340	200	196	125	5.5	70	47	78	255.5	0.39	2LC0111-4AB	61
380	7700	2000	61	140	60	165	380	230	226	140	5.5	74	51	83	285.5	0.69	2LC0111-5AB	86
430	10300	1700	66	150	65	180	430	250	246	160	5.5	78	56	88	325.5	1.2	2LC0111-6AB	120
472	13500	1550	80	160	80	190	472	265	261	180	7.5	86	64	99	367.5	1.9	2LC0111-7AB	161
514	16600	1400	90	180	90	215	514	300	296	190	7.5	90	65	104	387.5	2.9	2LC0111-8AB	206
556	21200	1300	100	190	100	225	556	315	310	210	7.5	102	68	115	427.5	4.1	2LC0112-0AB	256

Configurable variants ¹⁾

- ØD1 Without finished bore
With finished bore
- ØD2 Without finished bore
With finished bore

Ordering example

- N-EUPEX ADS coupling, size 135
- Part 1: Bore D1 42H7 mm, keyway to DIN 6885-1 and set screw
- Part 2: Bore D2 32H7 mm, keyway to DIN 6885-1 and set screw

Article no.: 2LC0110-5AB99-0AA0 L0X+M0T

Notes

- Weights and mass moments of inertia apply to maximum bores.

¹⁾ To identify complete item numbers specifying the available finish boring options and – if necessary – further order options, please use our configurators on flender.com.

↗ For online configuration on flender.com, click on the item no.

TYPE BDS

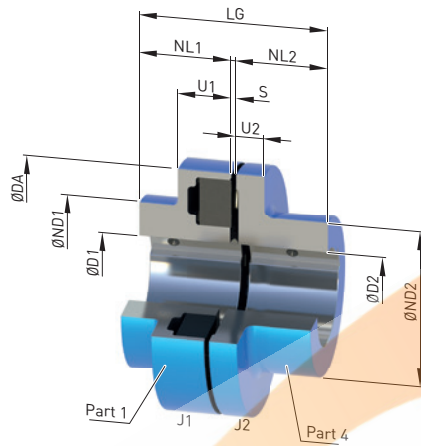

Size	Rated torque T_{KN} Nm	Speed n_{Kmax} rpm	Dimensions in mm											Mass moment of inertia J_1/J_2 kgm ²	Article no. ¹⁾	Weight m kg	
			Bore with keyway to DIN 6885-1				DA	ND1	ND2	NL1/ NL2	S	U1	U2				LG
			D1	D2	min. max.												
66	19	7500	-	20	-	25	66	66	40	20	3	20	8	43	0.0001	2LC0110-0AA	0.46
76	34	7000	-	28	-	30	76	76	50	20	3	20	8	43	0.0002	2LC0110-1AA	0.64
88	60	6000	-	35	-	42	88	88	68	30	3	30	10	63	0.0008	2LC0110-2AA	1.4
103	100	5500	-	45	-	48	103	76	76	35	3	30	12	73	0.0015	2LC0110-3AA	2.1
118	160	5300	-	50	-	55	118	86	86	40	3	34	14	83	0.003	2LC0110-4AA	3.0
135	240	5100	-	60	-	60	135	100	100	50	3	36	18	103	0.006	2LC0110-5AA	5.1
152	360	4900	-	65	-	65	152	108	100	55	3	36	20	113	0.009	2LC0110-6AA	6.4
172	560	4250	-	70	-	70	172	118	108	60	4	41	20	124	0.016	2LC0110-7AA	8.7
194	880	3800	-	80	-	80	194	135	125	70	4	44	20	144	0.028	2LC0110-8AA	13
218	1340	3400	-	85	-	85	218	150	140	80	4	47	24	164	0.052	2LC0111-0AA	19
245	2000	3000	-	90	-	90	245	150	150	90	4	52	18	184	0.078	2LC0111-1AA	24
272	2800	2750	46	100	46	100	272	165	165	100	5.5	60	18	205.5	0.13	2LC0111-2AA	32
305	3900	2450	49	110	54	110	305	180	180	110	5.5	65	20	225.5	0.21	2LC0111-3AA	43

Configurable variants¹⁾

- ØD1 Without finished bore
With finished bore
- ØD2 Without finished bore
With finished bore

Ordering example

- N-EUPEX BDS coupling, size 103
- Part 1: Bore D1 42H7 mm, keyway to DIN 6885-1 and set screw
- Part 4: Bore D2 32H7 mm, keyway to DIN 6885-1 and set screw

Article no.: 2LC0110-3AA99-0AA0 L0X+M0T

Notes

- Weights and mass moments of inertia apply to maximum bores.

¹⁾ To identify complete item numbers specifying the available finish boring options and – if necessary – further order options, please use our configurators on flender.com.

➤ For online configuration on flender.com, click on the item no.

TYPE HDS

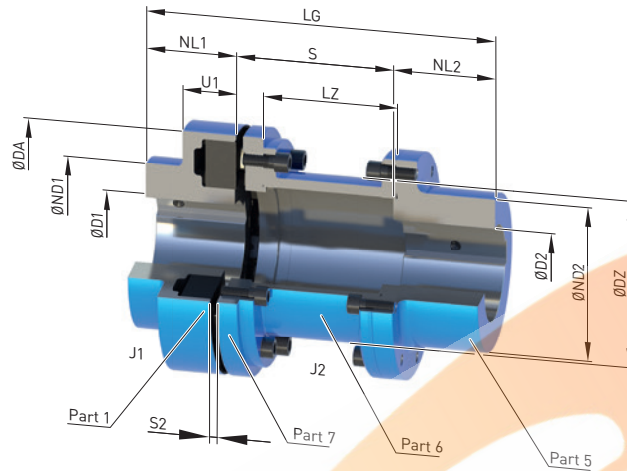

Size	Rated torque T_{KN} Nm	Speed n_{Kmax} rpm	Dimensions in mm														Mass moment of inertia		Article no. ¹⁾	Weight m kg
			Bore with keyway to DIN 6885-1			DA	ND1	ND2	NL1	NL2	S	S2	LZ	DZ	LG	J_1 kgm ²	J_2 kgm ²			
D1	D2		min.	max.	min.													max.		
88	60	6000	-	35	-	38 ²⁾	88	88	55	30	45	100	5	87	51	175	0.0007	0.0014	2LC0110-2AC	2.6
												140		127		215		0.0015		2LC0110-2AC
103	100	5500	-	45	-	48 ²⁾	103	76	70	35	45	100	5	87	63	180	0.001	0.0029	2LC0110-3AC	3.8
												140		127		220		0.0032		2LC0110-3AC
118	160	5300	-	50	-	55 ²⁾	118	86	80	40	50	140	5	85	73	190	0.003	0.0059	2LC0110-4AC	4.9
											60		180	165		280		0.0066		2LC0110-4AC
135	240	5100	-	60	-	60 ²⁾	135	100	90	50	50	140	5	85	85	200	0.006	0.01	2LC0110-5AC	7.3
											60		180	125		240		0.01		2LC0110-5AC
135	240	5100	-	60	-	60 ²⁾	135	100	90	50	60	180	5	165	85	290	0.006	0.012	2LC0110-5AC	8.2
											70		200	185		320		0.012		2LC0110-5AC
152	360	4900	-	65	-	65 ²⁾	152	108	100	55	65	180	5	82	91	300	0.011	0.02	2LC0110-6AC	10.8
											65		140	122		260		0.02		2LC0110-6AC
152	360	4900	-	65	-	65 ²⁾	152	108	100	55	65	180	5	162	91	300	0.011	0.022	2LC0110-6AC	11.8
											65		200	182		320		0.023		2LC0110-6AC
152	360	4900	-	65	-	65 ²⁾	152	108	100	55	80	250	5	232	91	385	0.011	0.024	2LC0110-6AC	12.6
											80		250	232		385		0.024		2LC0110-6AC

Configurable variants ¹⁾

- ØD1 Without finished bore
With finished bore
- ØD2 Without finished bore
With finished bore

¹⁾ To identify complete item numbers specifying the available finish boring options and – if necessary – further order options, please use our configurators on flender.com.

²⁾ For bore diameters greater than the following values, the feather key must be at least 3 mm behind the shaft end. Gr. 88 D2 > 32 mm; Gr. 103 D2 > 42 mm; Gr. 118 D2 > 50 mm; Gr. 135 D2 > 59 mm; Gr. 152 D2 > 64 mm.

↗ For online configuration on flender.com, click on the item no.

Size	Rated torque T_{KN} Nm	Speed n_{Kmax} rpm	Dimensions in mm														Mass moment of inertia		Article no. ¹⁾	Weight m kg			
			Bore with keyway to DIN 6885-1				DA	ND1	ND2	NL1	NL2	S	S2	LZ	DZ	LG	J_1 kgm ²	J_2 kgm ²					
			D1 min.	D1 max.	D2 min.	D2 max.																	
172	560	4250	-	70	-	70	172	118	108	60	70	100	81.5	230	0.019	0.03	2LC0110-7AC	13.8					
																	70	140	121.5	270	0.034	2LC0110-7AC	14.5
																	70	180	161.5	111	0.036	2LC0110-7AC	15.4
																	70	200	181.5	330	0.037	2LC0110-7AC	15.7
																	80	250	231.5	390	0.039	2LC0110-7AC	16.7
194	880	3800	-	80	-	80	194	135	125	70	80	140	121.5	290	0.037	0.057	2LC0110-8AC	20					
																	180	6	161.5	131	0.061	2LC0110-8AC	21
																	200	6	181.5	350	0.063	2LC0110-8AC	22
																	250	6	231.5	400	0.068	2LC0110-8AC	23
																	140	6	118.5	310	0.10	2LC0111-0AC	30
218	1340	3400	-	85	-	90	218	150	140	80	90	180	158.5	350	0.062	0.11	2LC0111-0AC	31					
																	200	6	178.5	144	0.11	2LC0111-0AC	32
																	250	6	228.5	420	0.12	2LC0111-0AC	33
																	140	6	118.5	330	0.16	2LC0111-1AC	34
																	180	6	158.5	370	0.17	2LC0111-1AC	35
245	2000	3000	-	90	-	95	245	150	150	90	100	200	178.5	390	0.09	0.18	2LC0111-1AC	36					
																	250	6	228.5	169	0.19	2LC0111-1AC	38
																	180	8	152.5	390	0.3	2LC0111-2AC	51
																	200	8	172.5	185	0.31	2LC0111-2AC	52
																	250	8	222.5	460	0.33	2LC0111-2AC	55
305	3900	2450	49	110	51	130	305	180	180	110	120	250	8	222.5	215	480	0.28	0.51	2LC0111-3AC	71			
340	5500	2150	49	120	51	140	340	200	200	125	140	250	8	222.5	246	515	0.50	0.85	2LC0111-4AC	101			
380	7700	2000	61	140	51	160	380	230	230	140	150	250	8	220.5	272	540	0.80	1.4	2LC0111-5AC	125			
430	10300	1700	66	150	51	180	430	250	250	160	180	250	8	185.5	311	590	1.4	2.4	2LC0111-6AC	195			
472	13500	1550	80	160	51	190	472	265	265	180	180	250	10	182	354	610	2.1	4.0	2LC0111-7AC	224			

Configurable variants¹⁾

- ØD1 Without finished bore
With finished bore
- ØD2 Without finished bore
With finished bore

Notes

- For dimension U1, see type ADS on page Page 7/32 and type BDS on page Page 7/33
- During assembly, the gap dimension S2 must not exceed the permissible tolerance of +1 mm.
- For sizes 305 to 472 the outer diameter of part 5 and part 7 is smaller than ØDA.
- Weights and mass moments of inertia apply to maximum bores.

Ordering example

- N-EUPEX HDS coupling, size 103, S = 100 mm
- Part 1: Bore D1 42H7 mm, keyway to DIN 6885-1 and set screw
- Part 5: Bore D2 32H7 mm, keyway to DIN 6885-1 and set screw
- Coupling micro-balanced G6.3 at 1500 rpm in accordance with half parallel key standard

Article no.: 2LC0110-3AC99-0AA0-Z L0X+M0T+W02+Y95
Plain text to Y95: G=6.3;n=1500rpm

¹⁾ To identify complete item numbers specifying the available finish boring options and – if necessary – further order options, please use our configurators on flender.com.

↗ For online configuration on flender.com, click on the item no.

SPARE AND WEAR PARTS

Elastomer flexibles of the N-EUPEX series

NBR elastomer flexibles 80 ShoreA standard type			
Size	Article No. (flexible set for one coupling)	Number of flexibles per set	Weight per set kg
58	2LC0170-0WA00-0AA0	4	0.012
68	2LC0170-1WA00-0AA0	5	0.015
80	2LC0170-2WA00-0AA0	6	0.02
95	2LC0170-3WA00-0AA0	6	0.03
110	2LC0170-4WA00-0AA0	6	0.045
125	2LC0170-5WA00-0AA0	6	0.06
140	2LC0170-6WA00-0AA0	6	0.09
160	2LC0170-7WA00-0AA0	7	0.12
180	2LC0170-8WA00-0AA0	8	0.17
200	2LC0171-0WA00-0AA0	8	0.23
225	2LC0171-1WA00-0AA0	8	0.3
250	2LC0171-2WA00-0AA0	8	0.38
280	2LC0171-3WA00-0AA0	8	0.55
315	2LC0171-4WA00-0AA0	9	0.7
350	2LC0171-5WA00-0AA0	9	0.85
400	2LC0171-6WA00-0AA0	10	1.2
440	2LC0171-7WA00-0AA0	10	1.5
480	2LC0171-8WA00-0AA0	10	2.1
520	2LC0172-0WA00-0AA0	10	2.6
560	2LC0172-1WA00-0AA0	10	3.6
610	2LC0172-2WA00-0AA0	10	4.9
660	2LC0172-3WA00-0AA0	10	6.3
710	2LC0172-4WA00-0AA0	10	7.6

HP elastomer flexibles for type DK/DKS (two-joint)			
Size	Article No. (flexible set for one coupling)	Number of flexibles per set	Weight per set kg
68	2LC0170-1VD00-0AA0	10	0.03
80	2LC0170-2VD00-0AA0	12	0.04
95	2LC0170-3VD00-0AA0	12	0.06
110	2LC0170-4VD00-0AA0	12	0.09
125	2LC0170-5VD00-0AA0	12	0.12
140	2LC0170-6VD00-0AA0	12	0.18
160	2LC0170-7VD00-0AA0	14	0.24
180	2LC0170-8VD00-0AA0	16	0.34
200	2LC0171-0VD00-0AA0	16	0.46
225	2LC0171-1VD00-0AA0	16	0.6
250	2LC0171-2VD00-0AA0	16	0.8
280	2LC0171-3VD00-0AA0	16	1.1

Notes

- The elastomer flexibles are wear parts. The service life depends on the operating conditions.

Elastomer flexibles of the N-EUPEX DS series

NBR elastomer flexibles standard type			
Size	Article No. (flexible set for one coupling)	Number of flexibles per set	Weight per set kg
66	2LC0110-0WA00-0AA0	4	0.012
76	2LC0110-1WA00-0AA0	5	0.015
88	2LC0110-2WA00-0AA0	6	0.021
103	2LC0110-3WA00-0AA0	6	0.033
118	2LC0110-4WA00-0AA0	6	0.048
135	2LC0110-5WA00-0AA0	6	0.072
152	2LC0110-6WA00-0AA0	6	0.1
172	2LC0110-7WA00-0AA0	7	0.16
194	2LC0110-8WA00-0AA0	8	0.21
218	2LC0111-0WA00-0AA0	8	0.28
245	2LC0111-1WA00-0AA0	8	0.45
272	2LC0111-2WA00-0AA0	8	0.64
305	2LC0111-3WA00-0AA0	8	0.72
340	2LC0111-4WA00-0AA0	9	0.92
380	2LC0111-5WA00-0AA0	9	1.2
430	2LC0111-6WA00-0AA0	10	1.6
472	2LC0111-7WA00-0AA0	10	2.0
514	2LC0111-8WA00-0AA0	10	2.5
556	2LC0112-0WA00-0AA0	10	3.2

Notes

- The elastomer flexibles are wear parts. The service life depends on the operating conditions.

Friction linings of the N-EUPEX type ERN

Friction linings, standard version			
Size	Article No. (set for one coupling)	Number of friction linings per set	Weight per set kg
80	2LC0170-2VK00-0AA0	2	0.05
95	2LC0170-3VK00-0AA0	2	0.06
110	2LC0170-4VK00-0AA0	2	0.06
125	2LC0170-5VK00-0AA0	2	0.10
140	2LC0170-6VK00-0AA0	2	0.12
160	2LC0170-7VK00-0AA0	2	0.12
180	2LC0170-8VK00-0AA0	2	0.23
200	2LC0171-0VK00-0AA0	2	0.34
225	2LC0171-1VK00-0AA0	2	0.34
250	2LC0171-2VK00-0AA0	2	0.60
280	2LC0171-3VK00-0AA0	2	0.66

Notes

- The friction linings are wear parts. The service life depends on the operating conditions.